

**IMPORTANT** The Kinetix MPL motor wiring examples on this page apply to motors equipped with circular DIN (SpeedTec) connectors.

**Figure 97 - AM Module Wiring Example with Kinetix MPL-B and MPM-A/B Resolver Motors**

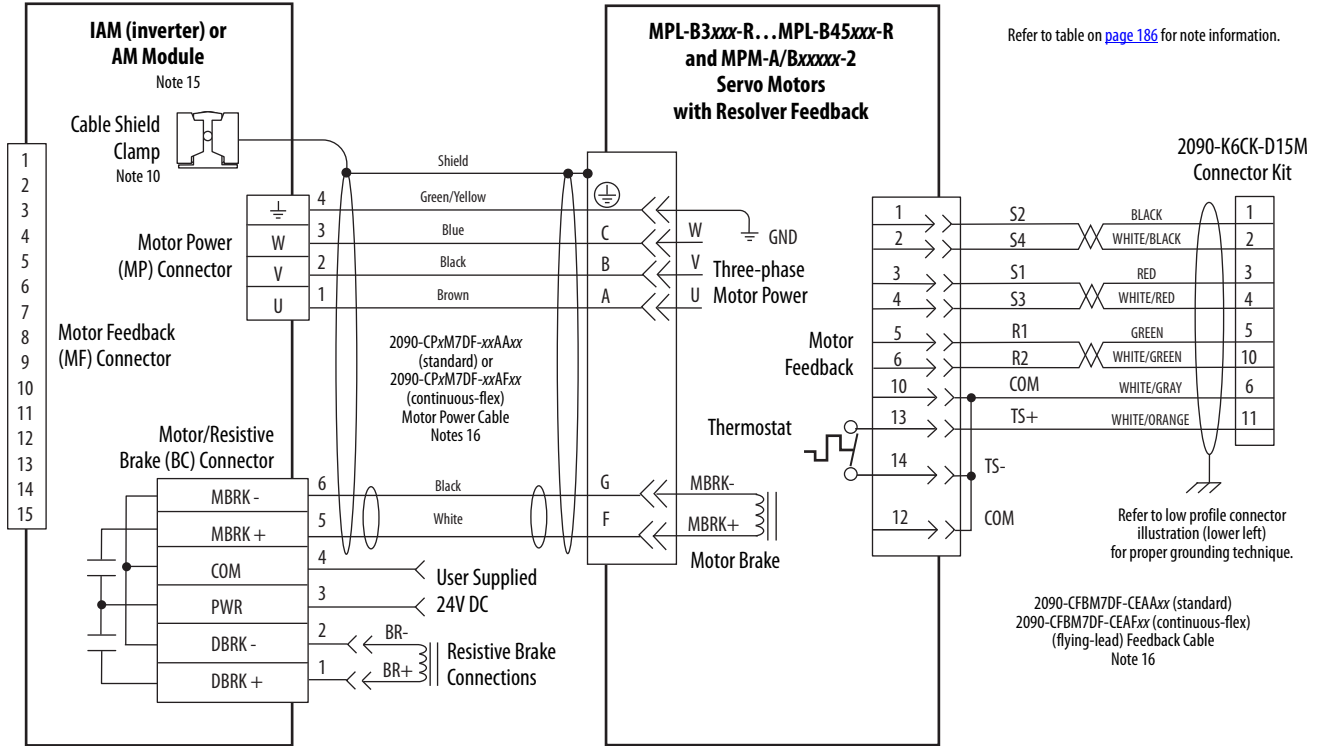

Circular DIN Connectors

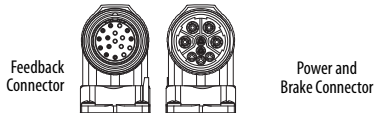

**Grounding Technique for Feedback Cable Shield**

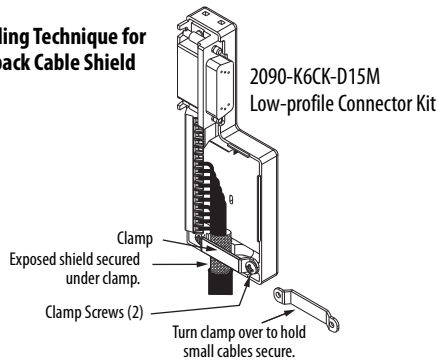

Refer to Low Profile Connector Kit Installation Instructions, publication [2094-IN007](#), for connector kit specifications.