



**ProvibTech**  
Innovative Machine Monitoring

# TR Series Vibration Transmitter

## User Manual

Installation, operation, maintenance





## Table of Content

TR4101 Proximity Loop-powered Transmitter for Shaft Vibration .....	3
Introduction.....	3
Installation .....	5
Operation.....	8
Maintenance.....	10
TR4102 Proximity Loop-powered Transmitter for Thrust Position .....	12
Introduction.....	12
Installation .....	14
Operation.....	17
Maintenance.....	19
TR5102 Proximity Speed and Phase Reference Transmitter .....	21
Introduction.....	21
Installation .....	23
Operation.....	25
Maintenance.....	27
TR1101 Vibration Transmitter with Acceleration, Velocity and Displacement .....	29
Introduction.....	29
Installation .....	31
Operation.....	32
Maintenance.....	33
TR3101 Three-Wire Transmitter for Shaft Vibration .....	35
Introduction.....	35
Installation .....	37
Operation.....	39
Maintenance.....	41
TR3102 Three-Wire Transmitter for Thrust Position .....	43
Introduction.....	43
Installation .....	45
Operation.....	47
Maintenance.....	48

---



## TR4101 Proximity Loop-powered Transmitter for Shaft Vibration

### Introduction

The TR4101 is a cost-effective solution for monitoring the radial vibration on the shaft of balance of plant machines. The TR4101 combines the proximity probe driver and the signal conditioning circuit into one package. It works with a proximity probe and extension cable as a system.

### Features

- ✓ **Loop powered transmitter**
- ✓ **Does not require proximity probe driver**
- ✓ **Buffered output/ GAP**
- ✓ **Compatible with other manufacturers' proximity probes (5mm, 8mm and 11mm)**
- ✓ **Aluminum cast case (copper free) with epoxy potting for better environmental protection and reliability**
- ✓ **Same size as a proximity probe driver**

### Specifications

#### Electrical

Power Supply:  
16-30VDC

Frequency Response ( $\pm 3$ dB):  
2.0 - 3,000Hz

Probe and Cable:

5 meter or 9 meter proximity probe and extension cable works with 5mm, 8mm, and 11mm probes

Proximity probe includes: TM0180, TM0105, TM0110, 3300, 7200 and 990 series

Sensor Linear Range (reference with AISI 4140 steel):

5mm, 8mm probe: 2.0 mm (80mil)  
Approximately 0.25mm (10mil) to 2.25mm (90mil)

11mm probe: 4.0mm (160mil)  
Approximately 0.4mm (15mil) to 4.4mm (175mil)

Overall Vibration:

4-20mA  
2-wire, load

Buffered Output/ GAP:

Original vibration, un-filtered  
Nominal: 2-18VDC  
Impedance: 20 k $\Omega$

Maximum cable distance: 3.0m (10ft)  
Sensitivity: 8.0mV/ $\mu$ m (200mV/mil) nominal

Maximum Load:

50 $\times$ (Vs-16)



### Electrical specifications continued

Where Vs is the system power supply

Isolation:

> 500Vrms; circuit to case

System OK:

System OK: output 4-20mA

System Not OK: output < 3.6mA

### Physical

Height: 75mm (2.95")

Weight: 0.5 kg (1.0 lb)

### Environmental

Temperature:

Operation: -40°C to +70°C

Storage: -40°C to +100°C

Humidity:

90% non-condensing

### Order Information

\* Factory default

Standard configuration:

**TR4101-A00-E00-G00-S00**

8mm probe:

**TM0180-07-00-05-10-02**

Extension cable:

**TM0181-040-00**

**TR4101-AXX-EXX-GXX-SXX**

**AXX: Full Scale**

A00\*: 0 - 200 $\mu$ m (8.0mil) pk-pk



## *Proximity Transmitters, and Seismic Vibration Transmitters*

A01: 0 - 500um (20mil) pk-pk  
A02: 0 - 100um (4.0mil) pk-pk  
A03: 0 - 250um (10mil) pk-pk  
A04: 0 - 630um (25mil) pk-pk  
A05: 0 - 125um (5.0mil) pk-pk

### **EXX: Probe and Cable (not included)**

E00\*: TM0180, 8mm Probe, 5m Cable  
E01: TM0180, 8mm Probe, 9m Cable  
E02: 3300, 8mm Probe, 5m Cable  
E03: 3300, 8mm Probe, 9m Cable  
E04: 7200, 8mm Probe, 5m Cable  
E05: 7200, 8mm Probe, 9m Cable  
E06: TM0105, 5mm Probe, 5m Cable  
E07: TM0105, 5mm Probe, 9m Cable  
E08: TM0110, 11mm Probe, 5m Cable  
E09: TM0110, 11mm Probe, 9m Cable  
E10: 3300, 11mm Probe, 5m Cable  
E11: 3300, 11mm Probe, 9m Cable  
E12: 7200, 11mm Probe, 5m Cable  
E13: 7200, 11mm Probe, 9m Cable  
E14: 3309 Probe, 5m Cable  
E15: 3309 Probe, 7m Cable

### **GXX: Mount**

G00\*: DIN rail mount  
G01: Plate mount

### **SXX: Hazardous Area**

S00\*: Without approval. CE  
S01: Multiple approvals  
ATEX: II 1 G EEx ia IIC T4  
@Ta=-40°C ~ +70°C

KEMA06ATEX0217X

CSA: Non-incendive, Class I, Div. 2,  
Groups A, B, C, D & T4

CSA: Intrinsically safe, Class I, Div. I,  
Groups A, B, C & D, T4

PCEC: Ex ia IIC T4

TR CU: 0Ex ia IIC T4 X

№ TC RU C-US.ГБ05.B.00477  
NANIO CCVE

CE Mark

### **TR4101 Accessories**

The TR4101 requires a proximity probe and extension cable to work as a system.

**TM0180:** 8mm probe

**TM0105:** 5mm probe

**TM0110:** 11mm probe

**TM0181:** Extension cable

**TM0200:** 3-1/2 digit display unit

**BNC-2:** BNC adaptor for portable data collector





## Installation

### Installation - Mounting the probe

There are two ways for probe's field installation:

- 1) Please mount the probe in axial direction for TR4101 Proximity Loop-powered Transmitter for Shaft Vibration monitoring system. Keep the distance between probe tip and shaft about 0.05" (1.25mm). In order to avoid wrong output, please make sure there is enough distance between probe tip and the other metal material which is monitored. The least distance is 0.63" (16mm), please refer to Figure 1. For exact gapping procedure see the section **Set-up Procedure** of chapter **Operation**. When mounting two probes adjacently, the two probes should keep 1" (25 mm) at least as shown in Figure 2.
- 2) Mount probe holder at the side of bearing as shown in figure 3. This method can easily adjust probe gap.

#### NOTE:

When inserting the probe through the machine case or bearing cap, the signal voltage may vary widely before the proper gap is obtained. Therefore, be sure the gap is within 0.07" (1.8mm) of the target before attempting to set the gap electrically.

Please refer to section **Order information** of chapter **Maintenance**. Do not change the length of the extension cable or delete it, as such action will adversely affect the calibration and linearity.

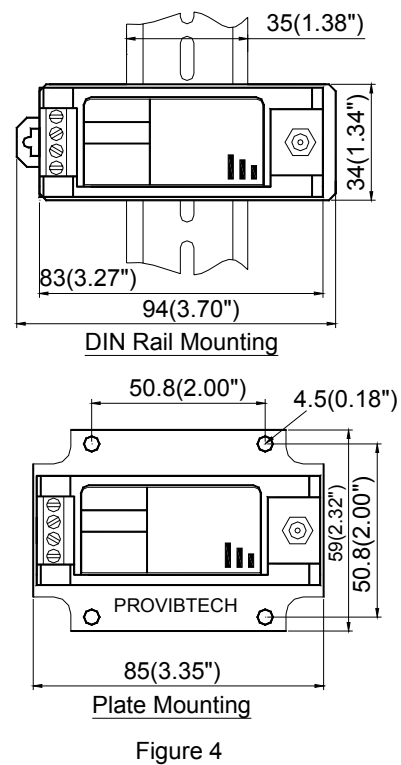
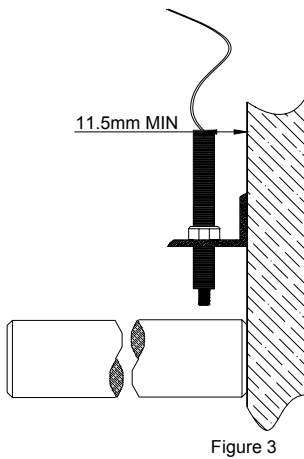
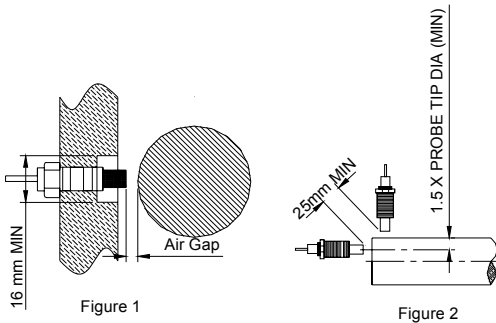

### Installation - Mounting the transmitter

The Figure 4 shows the unit with the optional mounting plate and mounting rail.



# Proximity Transmitters, and Seismic Vibration Transmitters

## Installation - Field Wiring

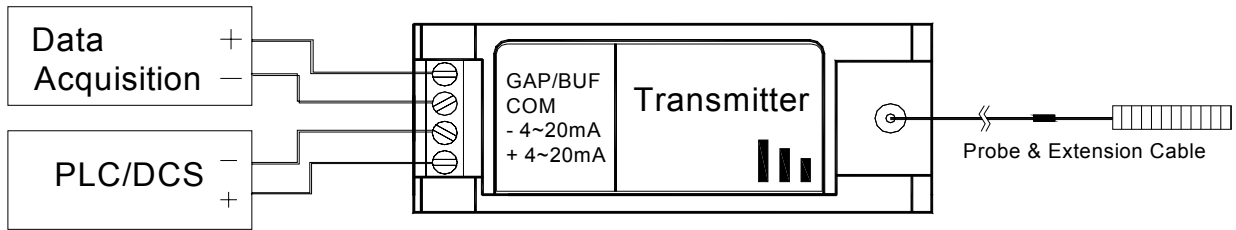

## Installation - Intrinsically Safe Installation

### Hazardous Area Marking

The label features the PVT logo at the top center. Below it is the brand name 'PROVIBTECH'. On the left, there is a 'C US' mark and the text 'INTRINSICALLY SAFE Class I, Div. 1, Grps. A, B, C & D, T4; Class I, Zone 0, Ex ia IIC T4; Non - incendive Class I Div. 2 Grps. A, B, C & D, T4 Enclosure 4X Certificate: 1878430'. In the center, there is a large empty rectangular box. On the right, there is an 'Ex' mark, the text 'KEMA 06ATEX0217X II 1 G EEx ia IIC T4', the 'Ex EAC' mark, and the text '0 Ex ia IIC T4 X № TC RU C-ON1505.B.00xxx NANIO CCVE'. At the bottom right is the 'CE' mark with the number '1344'. At the bottom center, the website 'www.provibtech.com' and address '11011 Brooklet Dr., Ste. 300, Houston, TX 77099, USA' are listed.

Explosion protection:

**CSA:** non-incendive, Class I, Div. 2, groups A/B/C/D T4  
Intrinsically safe, Class I, Div. 1, groups A/B/C/D T4;  
Class I, Zone 0, Ex ia IIC T4

**ATEX:** II 1 G, EEx ia IIC T4  
@Ta=-40°C ~ +70°C  
KEMA06ATEX0217X

TR CU: 0Ex ia IIC T4 X

№ TC RU C-US.ГБ05.B.00477  
NANIO CCVE

The label is divided into sections. On the left, there is a table with a diagonal hatched background:

GAPV/BUF	
COM	
-	4~20
+	mA

To the right of this table is the brand name 'PROVIBTECH' written vertically. Further right, the model 'TR4101' is displayed prominently, followed by '2-wire Vibration Transmitter'. Below this, 'POWER: +24V' is indicated. At the bottom, there are two circular symbols: a shaded one labeled 'ZERO' and an unshaded one labeled 'SPAN', followed by a bar graph icon.

### Input Parameters

$U_i$	28V
$I_i$	93mA
$P_i$	0.65W
$C_i$	4nF
$L_i$	0.7mH



# Proximity Transmitters, and Seismic Vibration Transmitters

## Special conditions

- The ambient temperature range is:  $-40^{\circ}\text{C} \leq T_a \leq 70^{\circ}\text{C}$
- Because the enclosure is made of aluminum alloy, an ignition source due to impact or friction between the enclosure and iron/steel must be avoided.

Because the mounting plate/din rail and probe cable outer jacket are made of non-metallic material, an ignition source due to electrostatic charging of the former must be avoided.

The barrier must fulfill the following requirements:  $U_o \leq U_i$ ,  $L_o \leq L_i$ ,  $P_o \leq P_i$ ,  $C_o > C_i + C_{\text{cable}}$ ,  $L_o > L_i + L_{\text{cable}}$   
 The enclosure should be earthed. When using an isolator, it can be realized by earthing the "COM".

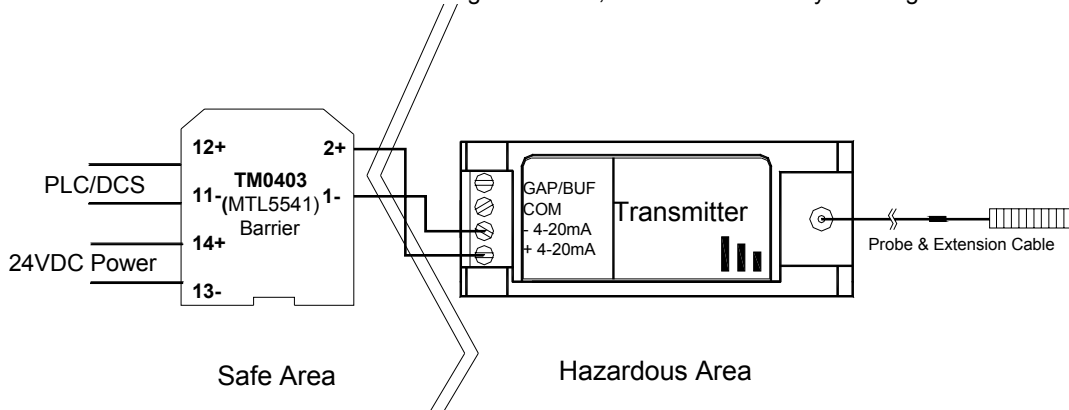

## Installation - TR4101 Field Wiring in Hazardous Area

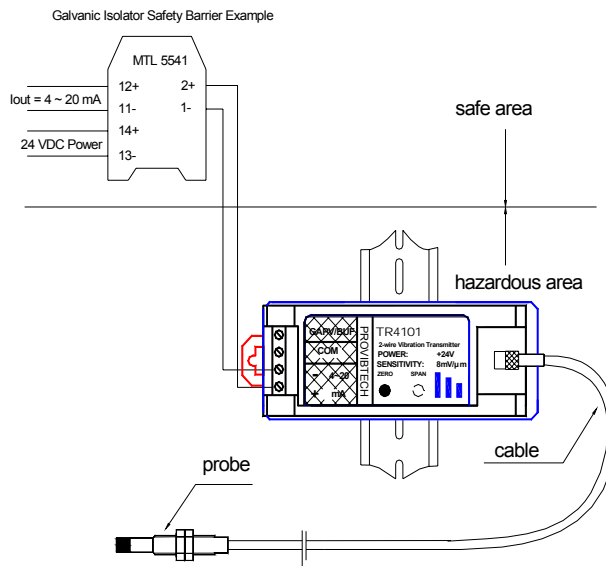

### Note:

1. Entity Installation:

Transmitter entity parameters are:  
 $U_i=28\text{V}$   $I_i=93\text{mA}$   $P_i=0.65\text{W}$   $C_i=4\text{nF}$   $L_i=0.7\text{mH}$

Choose a CSA certified barrier with entity parameters that satisfy the following conditions:

$$U_i \geq U_o \quad I_i \geq I_o \quad P_i \geq P_o \quad C_i + C_{\text{cable}} \leq C_o \quad L_i + L_{\text{cable}} \leq L_o$$

2. The associated apparatus must not be paralleled unless this is permitted by the associated apparatus approval.
3. Installation of the equipment shall be in accordance with the CEC section 18 and NEC Articles 504 and 505, and ISA RP 12.6 Recommend Practice for the Installation of Intrinsically Safe Circuits.
4. Intrinsically safe wiring in hazardous area used only in North America.



## Operation

### Power-up Inhibit

During power up, the vibration transmitter will be engaged in the self-test mode. The self-test will test the transducer OK, the vibration transmitter circuitry, and the system functionality. The total time is roughly 5 seconds. After the inhibit time, and the monitor tested OK, the output will be within the 4mA to 20mA range.

### Set-up Procedure – Utilize Voltmeter

Mount the probe against the shaft.

Connect the probe, the extension cable, and TR4101.

- 1) Connect the voltmeter to “GAP V” and “COM” on TR4101.
- 2) Turn the power of TR4101 on.
- 3) Gap the probe against the shaft; read the voltmeter until it shows **8V +/- 0.5V**.
- 4) Tighten the probe.

### 4mA Calibration Procedure

- 1) Remove the seal of “ZERO” from the top of the transmitter
- 2) Connect the right probe and extension cable.
- 3) Gap the probe properly (see Field Set-up).
- 4) Connect the transmitter to power and the measuring unit. (Current meter, display unit, PLC/DCS etc.).
- 5) Adjust the potential-meter until the current meter indicates a 4.0mA or a “0” from PLC/DCS.
- 6) Put the seal back.

### Full-Scale Calibration Procedure (for certified Engineer only)

Calibration of full-scale can only be done by experienced (certified) engineer. Special equipments are needed. Please contact with ProvibTech for more details.

- 1) Remove the seal of “ZERO” from the top of the transmitter.
- 2) Remove the top label.
- 3) Connect the TR transmitter, extension cable and eddy probe. Mounting the probe to the shaker, gap the eddy-probe to until the gap voltage shows 8V+/-0.1V.
- 4) With the shaker standstill, turn the “ZERO” potential-meter until the 4-20mA output indicates 4.0mA.
- 5) Turn the shaker to the full-scale vibration. Turn the “SPAN” potential-meter until the 4-20mA output indicates 20.0mA.
- 6) Repeat procedure 4) and 5) four times.
- 7) Put the label and the seal back to the transmitter.

#### CAUTION

**The 4-20mA output has been factory calibrated before the shipment. Unless you are sure you understand the conversion factor, and you have the special tools, otherwise, please do not try to calibrate it.**

The Proximity Loop-powered Transmitter System measures the radial vibration of a shaft or other part of a machine in relation to the location of the probe tip. The following equation represents the relationship between the vibration and the loop current:

$$\text{Vibration} = \frac{(\text{Current(mA)} - 4)}{16} * (\text{Full Scale Range})$$





## *Proximity Transmitters, and Seismic Vibration Transmitters*

EXAMPLE:

Measured ma	Full Scale Vibration	Actual Vibration
<3.6	5.0 mils, pk-pk	Probe Fault
4.0	5.0 mils, pk-pk	0.0 mils, pk-pk
12.0	5.0 mils, pk-pk	2.5 mils, pk-pk
20.0	5.0 mils, pk-pk	5.0 mils, pk-pk

### **Buffered Output / GAP V**

Buffered output will directly interface with any diagnostics or condition monitoring equipment. The buffered output will have the same unit as the overall vibration output.

#### **CAUTION**

- 1) **The buffered output can only drive 3 meters of cable from the TR transmitter to the data-collector. No more than 3 meters will be allowed.**
- 2) **It is not recommended that the diagnostics instrument be directly connected with the buffered output in the middle of the operation. This will likely be engaged in the ground loop problem and will possibly generate false vibration signal.**
- 3) **If you insist to connect the instrument to the buffered output during the machine operation, you must isolate the instrument from ground. In another word, you must make sure the diagnostics instrument and the Vibration transmitter only has one ground.**



## **Maintenance**

TR4101 is a high integrated vibration transmitter. The maintenance described here covers the test of the module and check whether it works properly and primary setting for measuring value.

This part describes vortex probe system monitoring and output current calibration.

Periodic maintenance

Maintenance tools

4mA Calibration Procedure

Exceptional module treatment

### **Periodic Maintenance**

This maintenance interval is very important for the module maintenance. Usually, a yearly maintenance is sufficient. If TR4101 works in extraordinary circumstance, user should shorten the interval according to the actual situation.

### **Extraordinary circumstance**

Used to monitor some critical equipment

High temperature, high humidity, and corrosive environment

### **Maintenance tools**

Multimeter

Screw driver

### **4mA Calibration Procedure**

- 1) Remove the seal of "ZERO" from the top of the transmitter.
- 2) Connect the right probe and extension cable.
- 3) Gap the probe properly (see Field Set-up).
- 4) Connect the transmitter to power and the measuring unit. (Current meter, display unit, PLC/DCS etc.).
- 5) Adjust the potential-meter until the current meter indicates a 4.0mA or a "0" from PLC/DCS.
- 6) Put the seal back.

### **CAUTION**

**The 4-20mA output has been factory calibrated before the shipment. Unless you are sure you understand the conversion factor, and you have the special tools, otherwise, please do not try to calibrate it.**

### **Exceptional Module Treatment**

In case of finding some exceptions after the test, except the linearity problem which can be solved by calibrating, users should not repair it by themselves. Users could substitute it with a spare TR4101 transmitter and contact with a ProvibTech local office.



### **Trouble shooting**

1. NOT OK :The 4-20mA output will be less than 3.6mA if the following conditions meet:
  - 1) Probe failure.
  - 2) Extension cable failure.
  - 3) Probe and extension cable are not connected to TR transmitter.
  - 4) Transmitter failure.
  - 5) Probe is not gapped in its linear range.



## TR4102 Proximity Loop-powered Transmitter for Thrust Position

### Introduction

The TR4102 is a cost-effective solution for monitoring the axial position or phase reference on balance of plant machines. The TR4102 combines the proximity probe driver and the signal conditioning circuit into one package. It works with a proximity probe and extension cable as a system.

### Features

- ✓ Loop powered transmitter
- ✓ Does not require proximity probe driver
- ✓ Buffered output/ GAP
- ✓ Compatible with other manufacturers' proximity probes (5mm, 8mm and 11mm)
- ✓ Aluminum cast case (copper free) with epoxy potting for better environmental protection and reliability
- ✓ Same size as a proximity probe driver

### Specifications

#### Electrical

DCS or PLC Power Supply:

16-30VDC

Sensor Interface:

Special 95Ω coaxial cable with connector

Probe:

5mm, 8mm, and 11mm probes which includes: TM0180, TM0105, TM0110, 3300, and 7200 series

Sensor Linear Range (reference with AISI 4140 steel):

5mm, 8mm probe: 2.0 mm (80mil)

Approximately 0.25mm (10mil) to 2.25mm (90mil)

11mm probe: 4.0mm (160mil)

Approximately 0.4mm (15mil) to 4.4mm (175mil)

4-20mA Transmissions:

2-wire, load

Phase reference: frequency response: 0 - 10 KHz (G02 and G03)

Buffered Output (GAP V):

Raw position signal

Nominal: 2-18VDC

Impedance: 20 KΩ

Maximum cable distance: 3.0m (10ft)

Sensitivity: 8.0mV/um (200mV/mil) nominal

Frequency response: 0 - 10 KHz



### Electrical specifications continued

Maximum Load:

50×(Vs-16)

Where Vs is the system power supply

System Self-test:

System OK: output 4-20mA

System Not OK: output < 3.6mA

### Physical

Height: 75mm (2.95")

Weight: 1.0kg (2.0 lbs)

### Environmental

Temperature:

Operation: -40°C to +70°C

Storage: -40°C to +100°C

Humidity:

90% non-condensing

### Order Information

\* Factory default

Standard configuration:

**TR4102-E00-G00-S00**

8mm probe:

**TM0180-07-00-05-10-02**

Extension cable:

**TM0181-040-00**

**TR4102-EXX-GXX-SXX**



## Proximity Transmitters, and Seismic Vibration Transmitters

### **EXX: Probe and Cable**

- E00\*: TM0180, 8mm Probe, 5m Cable
- E01: TM0180, 8mm Probe, 9m Cable
- E02: 3300, 8mm Probe, 5m Cable
- E03: 3300, 8mm Probe, 9m Cable
- E04: 7200, 8mm Probe, 5m Cable
- E05: 7200, 8mm Probe, 9m Cable
- E06: TM0105, 5mm Probe, 5m Cable
- E07: TM0105, 5mm Probe, 9m Cable
- E08: TM0110, 11mm Probe, 5m Cable
- E09: TM0110, 11mm Probe, 9m Cable
- E10: 3300, 11mm Probe, 5m Cable
- E11: 3300, 11mm Probe, 9m Cable
- E12: 7200, 11mm Probe, 5m Cable
- E13: 7200, 11mm Probe, 9m Cable
- E14: 3309 Probe, 5m Cable
- E15: 3309 Probe, 7m Cable

### **GXX: Mount/ Function**

- G00: DIN rail mount, measure position
- G01: Plate mount, measure position
- G02: DIN rail mount, measure phase
- G03: Plate mount, measure phase

### **SXX: Hazardous Area**

- S00\*: Without approval. CE
- S01: Multiple approvals  
ATEX: II 1 G EEx ia IIC T4

@Ta=-40°C ~ +70°C

KEMA06ATEX0217X

CSA: Non-incendive, Class I, Div. 2,  
Groups A, B, C, D & T4

CSA: Intrinsically safe, Class I, Div. I,  
Groups A, B, C & D, T4

PCEC: Ex ia IIC T4

TR CU: 0Ex ia IIC T4 X

№ TC RU C-US.ГБ05.B.00477

NANIO CCVE

CE Mark

### **TR4102 Accessories**

The TR4102 requires a proximity probe and extension cable to work as a system.

**TM0180:** 8mm probe

**TM0105:** 5mm probe

**TM0110:** 11mm probe

**TM0181:** Extension cable

**TM0200:** 3-1/2 digit display unit

**BNC-2:** BNC Adaptor for portable data collector





## Installation

### Installation - Mounting the probe

There are two ways for probe's field installation:

- 1) Please mount the probe in axial direction for TR4102 Proximity Loop-powered Transmitter for Thrust Position monitoring system. Keep the distance between probe tip and shaft about 0.05" (1.25mm). In order to avoid wrong output, please make sure there is enough distance between probe tip and the other metal material which is monitored. The least distance is 0.63" (16mm), please refer to Figure 1. For exact gapping procedure see the section **Set-up Procedure** of chapter **Operation**. When mounting two probes adjacently, the two probes should keep 1" (25 mm) at least as shown in Figure 2.
- 2) Mount probe holder at the side of bearing as shown in figure 3. This method can easily adjust probe gap.

NOTE:

When inserting the probe through the machine case or bearing cap, the signal voltage may vary widely before the proper gap is obtained. Therefore, be sure the gap is within 0.07" (1.8mm) of the target before attempting to set the gap electrically.

Please refer to section **Order information** of chapter **Maintenance**. Do not change the length of the extension cable or delete it, as such action will adversely affect the calibration and linearity.

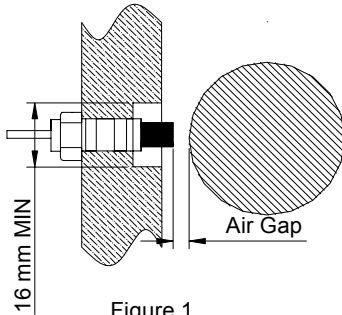

Figure 1

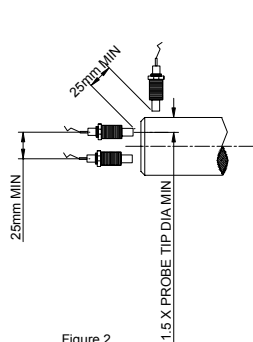

Figure 2

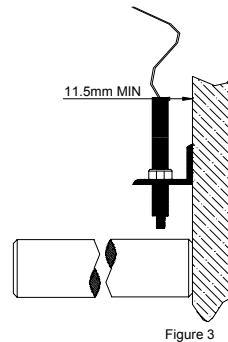
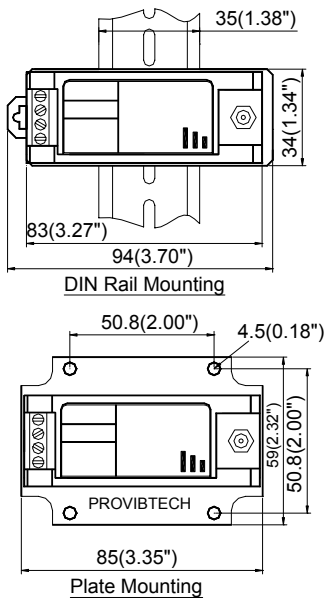

Figure 3

### Installation - Mounting the transmitter

The below drawing shows the unit with the optional mounting plate and mounting rail.





# Proximity Transmitters, and Seismic Vibration Transmitters

## Installation - Field-wiring Diagram

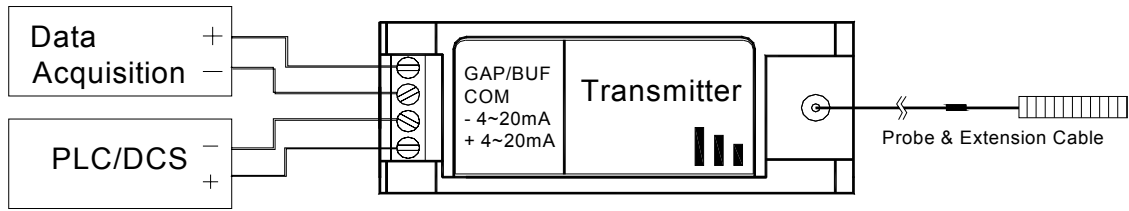

## Installation - Intrinsically Safe Installation

### Hazardous Area Marking

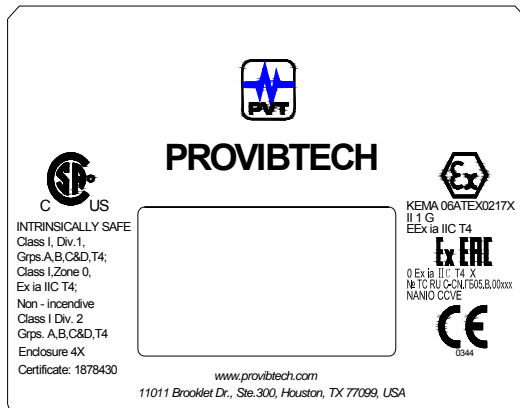

Explosion protection:

**ATEX:** II 1 G EEx ia IIC T4

KEMA 06ATEX0217X

**CSA:** non-incandive, Class I, Div. 2, groups A/B/C/D T4  
 Intrinsically safe, Class I, Div. 1, groups A/B/C/D T4; Class I, Zone 0, Ex ia IIC T4  
 TR CU: 0Ex ia IIC T4 X

№ TC RU C-US.ГБ05.B.00477  
 NANIO CCVE

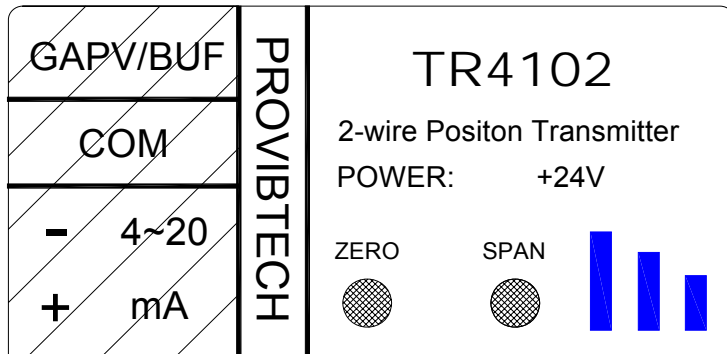

## Input Parameters

$U_i$	28V
$I_i$	93mA,
$P_i$	0.65W
$C_i$	4nF
$L_i$	0.2mH



## Proximity Transmitters, and Seismic Vibration Transmitters

### Special conditions

- The ambient temperature range is:  $-40^{\circ}\text{C} \leq T_a \leq 70^{\circ}\text{C}$
- Because the enclosure is made of aluminum alloy, an ignition source due to impact or friction between the enclosure and iron/steel must be avoided.

Because the mounting plate/din rail and probe cable outer jacket are made of non-metallic material, an ignition source due to electrostatic charging of the former must be avoided.

The barrier must fulfill the following requirements:

$$U_o \leq U_i, L_o \leq L_i, P_o \leq P_i, C_o > C_i + C_{\text{cable}}, L_o > L_i + L_{\text{cable}}$$

The enclosure should be earthed. When using an isolator, it can be realized by earthing the "COM".

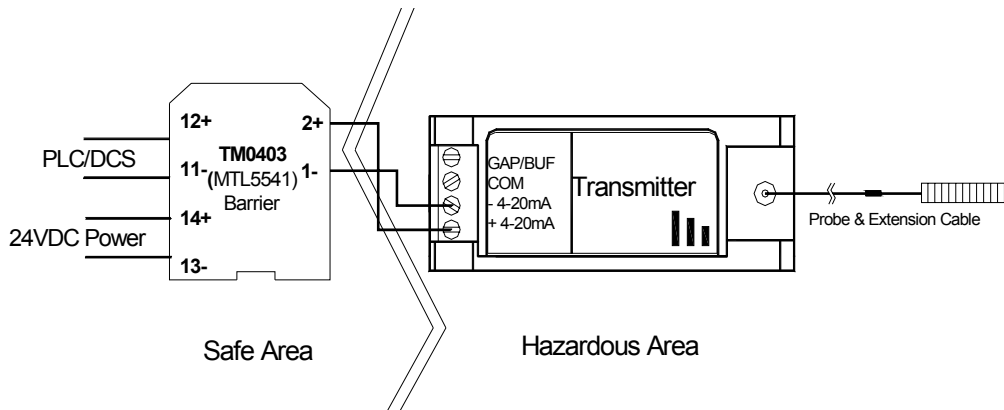

### Installation - Field Wiring in Hazardous Area

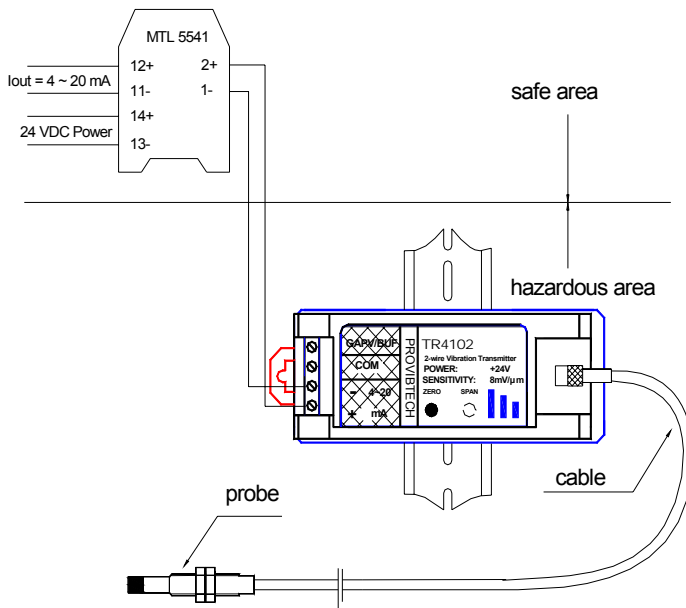

#### Note:

##### 1. Entity Installation:

Transmitter entity parameters are:

$$U_i = 28\text{V} \quad I_i = 93\text{mA} \quad P_i = 0.65\text{W} \quad C_i = 4\text{nF} \quad L_i = 0.7\text{mH}$$

Choose a CSA certified barrier with entity parameters that satisfy the following conditions:

$$U_i \geq U_o \quad I_i \geq I_o \quad P_i \geq P_o \quad C_i + C_{\text{cable}} \leq C_o \quad L_i + L_{\text{cable}} \leq L_o$$

2. The associated apparatus must not be paralleled unless this is permitted by the associated apparatus approval.
3. Installation of the equipment shall be in accordance with the CEC section 18 and NEC Articles 504 and 505, and ISA RP 12.6 Recommend Practice for the Installation of Intrinsically Safe Circuits.
4. Intrinsically safe wiring in hazardous area used only in North America.





## Operation

### Power-up Inhibit

During power up, the transmitter will be engaged in the self-test mode. The self-test will test the proximity probe system, the transmitter circuitry, and the system functionality. The total time is roughly 5 seconds. After the inhibit time, and the monitor tested OK, the output will be within the 4mA to 20mA range.

### Set-up Procedure – Utilize Voltmeter

- 1) Mount the probe against the shaft.
- 2) Connect the probe, the extension cable, and the TR4102.
- 3) Connect the voltmeter to GAP V and COM on TR4102.
- 4) Turn the power of TR4102 on.
- 5) Gap the probe against the shaft; read the voltmeter until it shows **10V +/- 0.25V**.
- 6) Tighten the probe.

### 4-20mA Calibration Procedure (for certified Engineer only)

Calibration of 4-20mA can only be done by experienced (certified) engineer. Special equipments are needed. Please contact with ProvibTech for more details.

- 1) Remove the seal of “ZERO” and “SPAN” from the top of the transmitter.
- 2) Connect the TR transmitter, extension cable and eddy probe. Mounting the probe to the static calibrator, gap the eddy-probe to until the gap voltage shows 10V. This is the center of the linear range. Note this “central gap”.
- 3) Turn the static-calibrator 1.0mm toward the probe tip from the “central gap”. Adjust the “ZERO” potential-meter until the 4-20mA output indicates 4.0mA.
- 4) Turn the static-calibrator 1.0mm away from the probe tip from the “central gap”. Adjust the “SPAN” potential-meter until the 4-20mA output indicates 20.0mA.
- 5) Repeat procedure 3) and 4) four times.
- 6) Put the seals back to the transmitter.

### CAUTION

**The 4-20mA output has been factory calibrated before the shipment. Unless you are sure you understand the conversion factor, and you have the special tools, otherwise, please do not try to calibrate it.**

The following equation represents the relationship between the target position and the loop current.

$$\text{Distance} = \frac{(\text{Current(mA)} - 12)}{8} * (\text{Full Scale Range})$$

Units: The transmitter current output is linearly proportional to the probe gap (Position) between 4 mA and 20 mA.

#### EXAMPLE:

Measured mA	Full Scale Vibration	Actual Vibration
<3.6	5.0 mils, pk-pk	Probe Fault
4.0	5.0 mils, pk-pk	-5.0 mils, pk-pk
12.0	5.0 mils, pk-pk	0 mils, pk-pk
20.0	5.0 mils, pk-pk	5.0 mils, pk-pk



### **Buffered Output / GAP V**

Buffered output will directly interface with any diagnostics or condition monitoring equipment. The buffered output will have the same unit as the overall vibration output.

#### **CAUTION**

1. The buffered output can only drive 3 meters of cable from the TR transmitter to the data-collector. No more than 3 meters will be allowed.
2. It is not recommended that the diagnostics instrument been directly connected with the buffered output in the middle of the operation. This will likely been engaged in the ground loop problem and will possibly generate false vibration signal.
3. If you insist to connect the instrument to the buffered output during the machine operation, you must isolate the instrument from ground. In another word, you must make sure the diagnostics instrument and the Vibration transmitter only has one ground.



## **Maintenance**

TR4102 is a high integrated Thrust Position transmitter. The maintenance described here covers the test of the module and check whether it works properly and primary setting for measuring value.

This part describes vortex probe system monitoring and output current calibration.

Periodic maintenance

Tool preparations

Current calibrating

Exceptional module treatment

### **Periodic Maintenance**

This maintenance interval is very important for the module maintenance. Usually, a yearly maintenance is sufficient. If TR4102 works in extraordinary circumstance, user should shorten the interval according to the actual situation.

### **Extraordinary circumstance**

Used to monitor some critical equipment

High temperature, high humidity, and corrosive environment

### **Maintenance tools**

Multimeter

Screw driver

### **4-20mA Calibration Procedure (for certified Engineer only)**

Calibration of 4-20mA can only be done by experienced (certified) engineer. Special equipments are needed. Please contact with ProvibTech for more details.

- 1) Remove the seal of "ZERO" and "SPAN" from the top of the transmitter.
- 2) Connect the TR transmitter, extension cable and eddy probe. Mounting the probe to the static calibrator, gap the eddy-probe to until the gap voltage shows 10V. This is the center of the linear range. Note this "central gap".
- 3) Turn the static-calibrator 1.0mm toward the probe tip from the "central gap". Adjust the "ZERO" potential-meter until the 4-20mA output indicates 4.0mA.
- 4) Turn the static-calibrator 1.0mm away from the probe tip from the "central gap". Adjust the "SPAN" potential-meter until the 4-20mA output indicates 20.0mA.
- 5) Repeat procedure 3) and 4) four times.
- 6) Put the seals back to the transmitter.

### **CAUTION**

**The 4-20mA output has been factory calibrated before the shipment. Unless you are sure you understand the conversion factor, and you have the special tools, otherwise, please do not try to calibrate it.**

### **Exceptional Module Treatment**

In case of finding some exceptions after the test, except the linearity problem which can be solved by calibrating, users should not repair it by themselves. Users could substitute it with a spare TR4102 transmitter and contact with a ProvibTech local office.



### **Trouble shooting**

1. NOT OK: The 4-20mA output will be less than 3.6mA if the following conditions meet:
  - 1) Probe failure.
  - 2) Extension cable failure.
  - 3) Probe and extension cable are not connected to TR transmitter.
  - 4) Transmitter failure.
  - 5) Probe is not gapped in its linear range.



## TR5102 Proximity Speed and Phase Reference Transmitter

### Introduction

TR5102 is a cost-effective solution for monitoring the speed on your balance of plant machines. TR5102 combines the proximity probe driver and the signal conditioning circuit into one package. It will work with proximity probe and extension cable as a system.

### Features

- ✓ **Loop power transmitter**
- ✓ **Does not require proximity probe driver**
- ✓ **Buffered output/GAP available for portable vibration analyzer**
- ✓ **Work with other manufactures 5mm, 8mm and 11mm probes**
- ✓ **Aluminum cast case with epoxy potting for hazardous area and reliability**
- ✓ **Same size as a proximity driver**

### Specifications

#### Electrical

Power Supply:

20-30VDC, 50mA.

Speed Response:

0 ~ 50,000 pulse per minute.

Sensor Interface:

Connection:

Special 95Ω coaxial cable with connector.

Probe:

5mm, 8mm, and 11mm probes that includes:

TM0180, TM0105, TM0110, 3300, 7200 series.

Buffered Output:

TTL output for speed and phase.

Nominal 0~ 5VDC.

Impedance: 100Ω.

Maximum cable distance: 300m (1000ft).

Overall Speed Output:

4-20mA, source.

Driving load resistance up to 750Ω.

#### Physical

Dimension: Height: 75mm (2.95"), see figuration.

Weight: 1.0kg (2.0 lb).

#### Environmental

Temperature:

Operation: -35°C ~ +70°C.

Storage: -40°C ~ +100°C.



Humidity:

90% non-condensing.

### Ordering Information

Standard configuration:

TR5102-A01-E00-F00-G00

8mm probe:

TM0180-A07-B00-C05-D10

Extension cable:

TM0181-A40-B00

### TR5102-AXX-EXX-FXX-GXX

#### AXX: Full Scale.

A00: 0 ~ 1,000 rpm

A01\*: 0 ~ 3,600 rpm

A02: 0 ~ 6,000 rpm

A03: 0 ~ 10,000 rpm

A04: 0 ~ 30,000 rpm

A05: 0 ~ 50,000 rpm

#### EXX: Probe and Cable.

E00\*: TM0180, 5m Cable

E01: TM0180, 9m Cable

E02: 8mm Probe, 3300, 5m Cable

E03: 8mm Probe, 3300, 9m Cable

E04: 8mm Probe, 7200, 5m Cable

E05: 8mm Probe, 7200, 9m Cable

E06: TM0105, 5m Cable

E07: TM0105, 9m Cable

E08: TM0110, 5m Cable

E09: TM0110, 9m Cable



## *Proximity Transmitters, and Seismic Vibration Transmitters*

E10: 11mm Probe, 3300, 5m Cable

E11: 11mm Probe, 3300, 9m Cable

E12: 11mm Probe, 7200, 5m Cable

E13: 11mm Probe, 7200, 9m Cable

**FXX: Teeth per Revolution.**

F00\*: 1

F02: Customer specify, number of teeth =XX

**GXX: Mounting.**

G00\*: DIN rail mounting.

G01: Plate mounting.

\* Denote factory default.

### **TR5102 Accessories**

TR5102 must works with proximity probe transducer.

**TM0180:** 8mm probe.

**TM0105:** 5mm probe.

**TM0181:** Extension cable.



## Installation

### Installation - Mounting the probe

There are two ways for probe's field installation:

Please mount the probe in axial direction for TR5102 Proximity Speed and Phase Reference Transmitter monitoring system. Keep the distance between probe tip and shaft about 0.05" (1.25mm). In order to avoid wrong output, please make sure there is enough distance between probe tip and the other metal material which is monitored. For exact gapping procedure see the section **Set-up Procedure** of chapter **Operation**. When mounting two probes adjacently, the two probes should keep 1" (25 mm) at least as shown in Figure 1.

NOTE:

When inserting the probe through the machine case or bearing cap, the signal voltage may vary widely before the proper gap is obtained. Therefore, be sure the gap is within 0.07" (1.8mm) of the target before attempting to set the gap electrically.

Please refer to section **Order information** of chapter **Maintenance**. Do not change the length of the extension cable or delete it, as such action will adversely affect the calibration and linearity.

### Installation Drawings

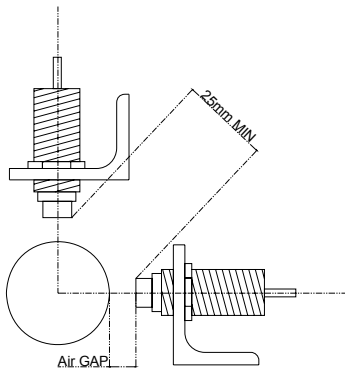

Figure 1

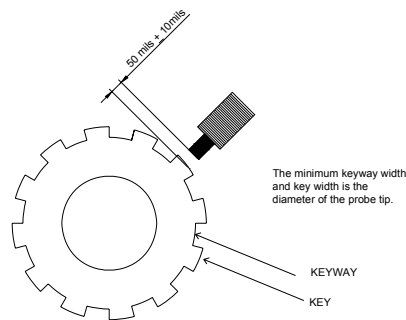
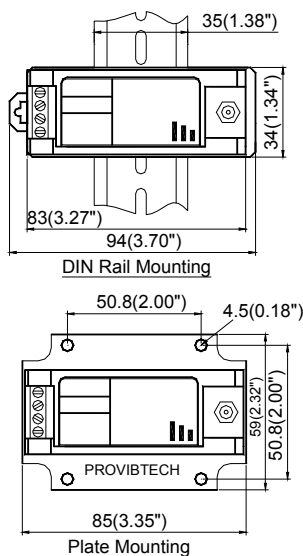

Figure 2

### Installation - Mounting the transmitter

The below drawing shows the unit with the optional mounting plate and mounting rail.





*Proximity Transmitters, and Seismic Vibration Transmitters*

**Installation - Field-wiring Diagram**

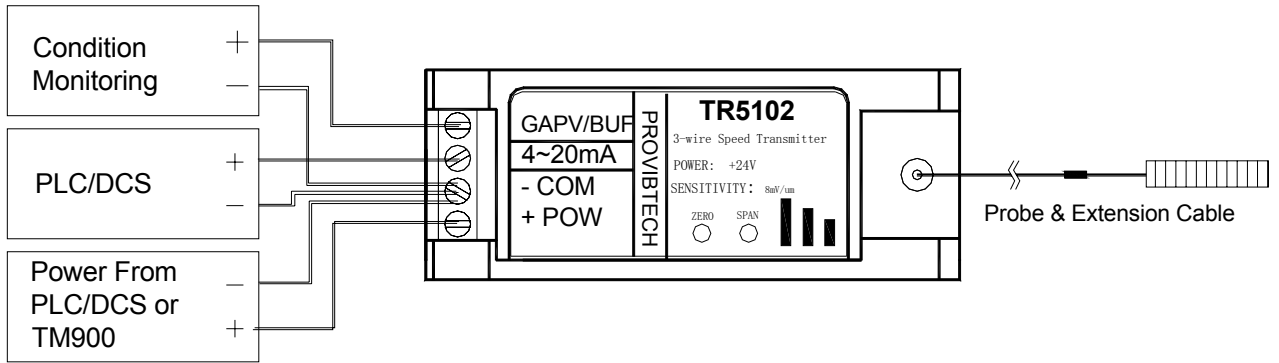





### Operation

#### Power-up Inhibit

During power up, the Proximity Speed and Phase Reference transmitter will be engaged in the self-test mode. The self-test will test the transducer OK, the vibration transmitter circuitry, and the system functionality. The total time is roughly 5 seconds. After the inhibit time, and the monitor tested OK, the output will be within the 4mA to 20mA range.

#### Set-up Procedure – Utilize Voltmeter

- 1) Mount the probe against the shaft.
- 2) Connect the probe, the extension cable, and TR5102.
- 3) Connect the voltmeter to “GAP V” and “COM” on TR5102.
- 4) Turn the power of TR5102 on.
- 5) Gap the probe against the shaft; read the voltmeter until it shows **10V +/- 0.5V**.
- 6) Tighten the probe.

#### 4mA Calibration Procedure

- 1) Remove the seal of “ZERO” from the top of the transmitter.
- 2) Connect the right probe and extension cable.
- 3) Gap the probe properly (see Field Set-up).
- 4) Connect the transmitter to power and the measuring unit. (Current meter, display unit, PLC/DCS etc.).
- 5) Adjust the potential-meter until the current meter indicates a 4.0mA or a “0” from PLC/DCS.
- 6) Put the seal back.

#### Full-Scale Calibration Procedure (for certified Engineer only)

Calibration of full-scale can only be done by experienced (certified) engineer. Special equipments are needed. Please contact with ProvibTech for more details.

- 1) Remove the seal of “ZERO” from the top of the transmitter.
- 2) Remove the top label.
- 3) Connect the TR transmitter, extension cable and eddy probe. Mounting the probe to the shaker, gap the eddy-probe to until the gap voltage shows 8V+/-0.1V.
- 4) With the shaker standstill, turn the “ZERO” potential-meter until the 4-20mA output indicates 4.0mA.
- 5) Turn the shaker to the full-scale frequency (If the full scale is 0-6000RPM and teeth per cycle is 1, the frequency range is 0-100Hz). Turn the “SPAN” potential-meter until the 4-20mA output indicates 20.0mA.
- 6) Repeat procedure 4) and 5) four times.
- 7) Put the label and the seal back to the transmitter.

### CAUTION

**The 4-20mA output has been factory calibrated before the shipment. Unless you are sure you understand the conversion factor, and you have the special tools, otherwise, please do not try to calibrate it.**

The TR5102 Proximity Speed and Phase Reference Transmitter System measures the RPM of a shaft or other part of a machine in relation to the location of the probe tip. The following equation represents the relationship between the RPM and the loop current.



$$\text{RPM} = \frac{(\text{Current(mA)} - 4)}{16} * (\text{Full Scale RPM})$$

During normal operation with RPM input, the transmitter current output is linearly proportional to the full scale RPM range between 4 mA and 20 mA.

**EXAMPLE:**

Measured ma	Full Scale RPM	Actual RPM
<3.6	100,000	Probe Fault
4.0	100,000	<100
12.0	100,000	50,000
20.0	100,000	100,000

### Buffered Output / GAP V

Buffered output will directly interface with any diagnostics or condition monitoring equipment. The buffered output will have the same unit as the overall vibration output.

### CAUTION

- 1) It is not recommended that the diagnostics instrument be directly connected with the buffered output in the middle of the operation. This will likely be engaged in the ground loop problem and will possibly generate false vibration signal.
- 2) If you insist to connect the instrument to the buffered output during the machine operation, you must isolate the instrument from ground. In another word, you must make sure the diagnostics instrument and the Vibration transmitter only has one ground.



## **Maintenance**

TR5102 is a high integrated Proximity Speed and Phase Reference transmitter. The maintenance described here covers the test of the module and check whether it works properly and primary setting for measuring value.

This part describes vortex probe system monitoring and output current calibration.

Periodic maintenance

Maintenance tools

4mA Calibration Procedure

Exceptional module treatment

### **Periodic Maintenance**

This maintenance interval is very important for the module maintenance. Usually, a yearly maintenance is sufficient. If TR5102 works in extraordinary circumstance, user should shorten the interval according to the actual situation.

### **Extraordinary circumstance**

Used to monitor some critical equipment

High temperature, high humidity, and corrosive environment

### **Maintenance tools**

Multimeter

Screw driver

### **4mA Calibration Procedure**

- 1) Remove the seal of "ZERO" from the top of the transmitter.
- 2) Connect the right probe and extension cable.
- 3) Gap the probe properly (see Field Set-up).
- 4) Connect the transmitter to power and the measuring unit. (Current meter, display unit, PLC/DCS etc.).
- 5) Adjust the potential-meter until the current meter indicates a 4.0mA or a "0" from PLC/DCS.
- 6) Put the seal back.

### **CAUTION**

**The 4-20mA output has been factory calibrated before the shipment. Unless you are sure you understand the conversion factor, and you have the special tools, otherwise, please do not try to calibrate it.**

### **Exceptional Module Treatment**

In case of finding some exceptions after the test, except the linearity problem which can be solved by calibrating, users should not repair it by themselves. Users could substitute it with a spare TR5102 transmitter and contact with a ProvibTech local office.



**Trouble shooting**

1. NOT OK: The 4-20mA output will be less than 3.6mA if the following conditions meet:
  - 1) Probe failure.
  - 2) Extension cable failure.
  - 3) Probe and extension cable are not connected to TR transmitter.
  - 4) Transmitter failure.
  - 5) Probe is not gapped in its linear range.



## TR1101 Vibration Transmitter with Acceleration, Velocity and Displacement

### Introduction

#### Condition Monitoring

- ✓ Measuring any rotation machinery case vibration.
- ✓ System can be used in hazardous area.

#### Output

- ✓ 4-20mA, source.
- ✓ Acceleration, velocity or displacement
- ✓ Buffered Output for condition monitoring
- ✓ System powered by DCS/PLC or TM900

#### DCS/PLC Interface

Due to the fact that transmitter does not supply alarm function, the PLC or DCS should be configured with some recommendation for alarming and vibration monitoring as follows:

- ✓ **Bypass on start-up:** Some machine will have large vibration on start-up, especially while passing the machine harmonic speed, sometimes, it is recommended to have a bypass on alarm during start-up.
- ✓ **Alarm timed-defeat:** For reliable alarming of machine vibration, you must eliminate the interference due to radio, electric-static discharge etc. API670 normally requires a timed-defeat. The delay time is normally between 1 to 6 seconds that will be determined by field condition.
- ✓ **System self-test:** If there is a defect on probe, extension cable or the transmitter, the 4-20mA will give a current which less than 3.6mA. In this situation, alarm should be disabled.

### Specifications

#### Electrical

Power Supply:

22-30VDC, 100mA (Non-isolated)

Frequency Response ( $\pm 3$ dB):

Acceleration: 2.0 - 10 KHz

Velocity: 2 - 10 KHz (velocity sensor)

Velocity: 10 - 5 KHz (accelerometer)

Displacement: 10 - 3 KHz (velocity sensor)

Acceleration (low frequency): 1.0 - 100Hz

Velocity (low frequency): 1.0 - 100Hz (TM079VD)

Displacement (low frequency): 1.0 - 100Hz (TM079VD)

Sensor Interface:

Sensitivity:

100mV/g nominal for accelerometer or

4.0mV/mm/sec (100mV/in/sec) nominal for velocity sensor



40mV/mm/sec (1000mV/in/sec) nominal for velocity  
TM079VD or 4mV/ $\mu$ m (100mV/mil) nominal for displacement TM079VD

Current Source:

Nominal 4mA@24VDC

Connectors:

GAP/Buf: gap and buffered output

SIG: sensor signal

COM: signal com

4-20mA: 4-20mA output

Buffered Output:

Original vibration, un-filtered

Impedance: 100 $\Omega$

Maximum cable distance: 300m (1,000ft)

Sensitivity: same as the sensor

Overall Vibration:

4-20mA, source

Driving load resistance up to 750 $\Omega$

System Self-test:

System OK: output 4-20mA

System Not OK: output < 3.0mA

#### Physical

Height: 75mm (2.95")

Weight: 1.0kg (2.0 lbs)

#### Environmental

Temperature:

Operation: -40°C to +70°C

Storage: -40°C to +100°C

Humidity:

90% non-condensing



**Order Information**

\*Factory Default

**TR1101-AXX-EXX-GXX**

**AXX: Full Scale**

- A00\*: 0 - 200um pk-pk
- A01: 0 - 500um pk-pk
- A02: 0 - 100um pk-pk
- A03: 0 - 10mil pk-pk
- A04: 0 - 25mil pk-pk
- A05: 0 - 5.0mil pk-pk
- A06: 0 - 50mm/s pk
- A07: 0 - 100mm/s pk
- A08: 0 - 20mm/s pk
- A09: 0 - 2.0ips pk
- A10: 0 - 4.0ips pk
- A11: 0 - 1.0ips pk
- A12: 0 - 5.0g pk
- A13: 0 - 10g pk
- A14: 0 - 5.0g pk (low frequency)
- A15: 0 - 10g pk (low frequency)
- A16: 0 - 50mm/s pk (low frequency, E01, E04)
- A17: 0 - 100mm/s pk (low frequency, E01, E04)
- A18: 0 - 500um pk-pk (low frequency, E04)
- A19: 0 - 200um pk-pk (low frequency, E04)
- A20: 0 - 2.0ips pk (low frequency, E04)
- A21: 0 - 4.0ips pk (low frequency, E01, E04)
- A22: 0 - 20mil pk-pk (low frequency, E04)
- A23: 0 - 10mil pk-pk (low frequency, E04)

**AXX: Full Scale continued**

- A24: 0 - 2.0ips (50 mm/s) rms
- A25: 0 - 1.0ips (25 mm/s) rms
- A26: 0 - 0.8ips (20 mm/s) rms
- A27: 0 - 0.5ips (12.5 mm/s) rms

**EXX: Sensor Type (not included)**

- E00\*: Accelerometer TM0782A, TM0783A, TM0784A, TM0785A, TM0786A or any current mode accelerometer with 100mV/g
- E01: Velocity sensor TM0793V, TM0796V or any current mode velocity sensor with 4mV/mm/sec
- E02: 330500, 330525 velocity sensor
- E03: 330750 velocity sensor
- E04: TM079VD low frequency sensor

**GXX: Mount**

- G00\*: DIN rail mount
- G01: Plate mount

**TR1101 Accessories**

The TR1101 requires an external accelerometer or velocity sensor to work as a system.

**TM0782A, TM0783A, TM0784A, TM0785A, TM0786A:** Accelerometer

**TM0793V, TM0796V:** Velocity sensor

**TM079VD:** Low frequency velocity and displacement sensor

**TM900:** Power converter

**TM0200:** 3-1/2 digit display unit



## Installation

### Installation - Sensor Installation

Only need to mill a flat base of 30mm in diameter, and drill a M6 hole in the middle to install the sensor. No need to do anything inside the machine.

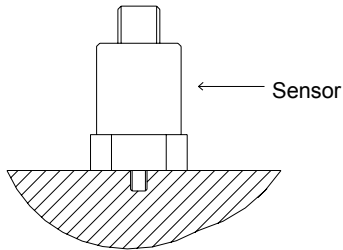

### Installation - Mounting the transmitter

The below drawing shows the unit with the optional mounting plate and mounting rail.

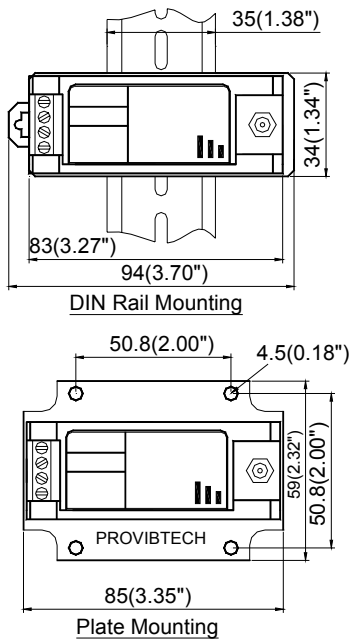

### Installation - Field-wiring Diagram

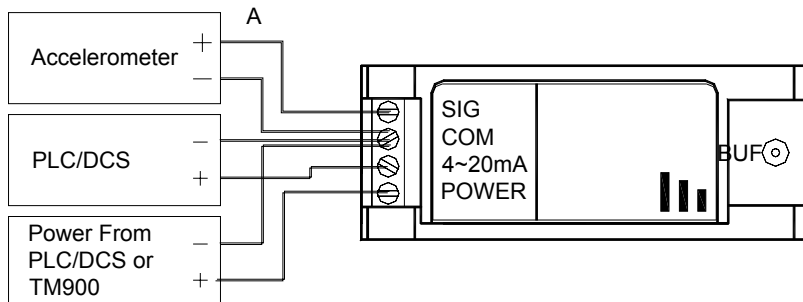



## Operation

### Power-up

During power-up, the Transmitter-Monitor will engage in the self-test mode. The self-test will test the transducer OK, the Transmitter-Monitor circuitry. The total time is roughly 6 seconds. After the inhibit time period, the green OK LED will be on

### 4-20mA Calibration Procedure (For Certified Engineer Only)

The main task for calibration is to adjust the "ZERO" and "SPAN" to conform to the output 4-20mA. This can only be done by experienced (certified) engineer with special tools. Please contact with ProvibTech for more details.

- 1) Remove the seal of "ZERO" and "SPAN" from the top of the transmitter.
- 2) Connect the driver, extension cable and Accelerometer to shaker.
- 3) With the shaker stand-still, turn the "ZERO" potential-meter till the 4-20mA output indicating 4.00mA.
- 4) Turn the shaker to the full-scale vibration. Turn the "SPAN" potential-meter on the side of right corner of the monitor, till the 4-20mA output indicating 20.0mA.
- 5) Repeat procedure 3) and 4) four times.
- 6) Put the seal back to normal.

#### CAUTION

**The 4-20mA output has been factory calibrated before the shipment. Unless you are sure you understand the conversion factor, and you have the special tools, otherwise, please do not try to calibrate it.**

### Buffer Output

Buffer output can directly interfere with any diagnoses or the condition of monitoring equipment. The Buffer output also has the same unit as the overall vibration output.

#### CAUTION

**It is not recommended that the diagnostic instrument been directly connected with the Buffer output during the operation. This may be likely to lead the ground loop problem and may possibly generate false vibration signal.**

**If you insist on connecting the instrument to the Buffer output during the machine operation, you must isolate the instrument from ground. In other words, you must make sure the diagnostic instrument and the Transmitter-Monitor share one ground.**





## **Maintenance**

TR1101 is a high integrated vibration transmitter. The maintenance described here covers the test of the module and check whether it works properly and primary setting for measuring value.

This part describes vortex probe system monitoring and output current calibration.

Periodic maintenance

Maintenance tools

4mA Calibration Procedure

Exceptional module treatment

### **Periodic Maintenance**

This maintenance interval is very important for the module maintenance. Usually, a yearly maintenance is sufficient. If TR1101 works in extraordinary circumstance, user should shorten the interval according to the actual situation.

### **Extraordinary circumstance**

Used to monitor some critical equipment

High temperature, high humidity, and corrosive environment

### **Maintenance tools**

Multimeter

Screw driver

### **4-20mA Calibration Procedure (For Certified Engineer Only)**

The main task for calibration is to adjust the "ZERO" and "SPAN" to conform to the output 4-20mA. This can only be done by experienced (certified) engineer with special tools. Please contact with ProvibTech for more details.

- 1) Remove the seal of "ZERO" and "SPAN" from the top of the transmitter.
- 2) Connect the driver, extension cable and Accelerometer to shaker.
- 3) With the shaker stand-still, turn the "ZERO" potential-meter till the 4-20mA output indicating 4.00mA.
- 4) Turn the shaker to the full-scale vibration. Turn the "SPAN" potential-meter on the side of right corner of the monitor, till the 4-20mA output indicating 20.0mA.
- 5) Repeat procedure 3) and 4) four times.
- 6) Put the seal back to normal.

#### **CAUTION**

**The 4-20mA output has been factory calibrated before the shipment. Unless you are sure you understand the conversion factor, and you have the special tools, otherwise, please do not try to calibrate it.**

### **Exceptional Module Treatment**

In case of finding some exceptions after the test, except the linearity problem which can be solved by calibrating, users should not repair it by themselves. Users could substitute it with a spare TR1101 transmitter and contact with a ProvibTech local office.



### **Trouble shooting**

1. NOT OK: The OK LED will remain on:
  - 1) Power supply failure.
  - 2) Transducer failure.
  - 3) Field wiring from the transducer to the Transmitter-Monitor shorted or opened.
  - 4) Transmitter-Monitor internal circuitry failure.



## TR3101 Three-Wire Transmitter for Shaft Vibration

### Introduction

#### Condition Monitoring

Measuring the rotation machinery shaft vibration. Monitoring the vibration increase due to shaft imbalance, misalignment, looseness etc.

#### Machine Type

All kinds of rotation machines with sleeve bearing. Such as blower, compressor, pump, gearbox, and power generators etc.

#### Output

- ✓ 4-20mA.
- ✓ Buffered Output, interface with portable or on-line data collector.
- ✓ System powered by DCS/PLC or TM900.

#### DCS/PLC Interface

Due to the fact that transmitter does not supply alarm function, the PLC or DCS should be configured with some recommendation for alarming and vibration monitoring as follows:

- ✓ **Bypass on start-up:** Some machine will have large vibration on start-up, especially while passing the machine harmonic speed, sometimes, it is recommended to have a bypass on alarm during start-up.
- ✓ **Alarm timed-defeat:** For reliable alarming of machine vibration, you must eliminate the interference due to radio, electric-static discharge etc. API670 normally requires a timed-defeat. The delay time is normally between 1 to 6 seconds that will be determined by field condition.
- ✓ **System self-test:** If there is a defect on probe, extension cable or the transmitter, the 4-20mA will give a current which less than 3.75mA. In this situation, alarm should be disabled.

### Specifications

#### Electrical

Power Supply:  
20-30VDC

Frequency Response ( $\pm 3dB$ ):  
2.0 - 3,000Hz

Probe and cable:

5 meter or 9 meter proximity probe and extension cable works with 5mm, 8mm, and 11mm probes  
Proximity probe includes: TM0180, TM0105, TM0110, 3300, 7200, 990 series

Sensor Linear Range (reference with ANSI 4140 steel):

5mm, 8mm probe: 2.0 mm (80mil)  
Approximately 0.25mm (10mil) to 2.25mm (90mil)



11mm probe: 4.0mm (160mil)

Approximately 0.4mm (15mil) to 4.4mm (175mil)

Overall Vibration:

4-20mA; Source

Buffered Output/ GAP:

Original vibration, un-filtered

Nominal: 2-18VDC

Impedance: 100 $\Omega$

Maximum cable distance: 300m (1,000ft)

Sensitivity: 8.0mV/ $\mu m$  (200mV/mil) nominal

Maximum Load:

500 $\Omega$

Isolation:

> 500Vrms; circuit to case

System OK:

System OK: output 4-20mA

System Not OK: output < 3.0mA

#### Physical

Height: 75mm (2.95")

Weight: 0.5 kg (1.0 lb)

#### Environmental

Temperature:

Operation: -40°C to +70°C

Storage: -40°C to +100°C

Humidity:

90% non-condensing

#### Order Information

\* Factory default

Standard configuration:



## *Proximity Transmitters, and Seismic Vibration Transmitters*

### **TR3101-A00-E00-G00-S00**

8mm probe:

### **TM0180-07-00-05-10-02**

Extension cable:

### **TM0181-040-00**

### **TR3101-AXX-EXX-GXX-SXX**

#### **AXX: Full Scale**

- A00\*: 0 - 200um (8.0mil) pk-pk
- A01: 0 - 500um (20mil) pk-pk
- A02: 0 - 100um (4.0mil) pk-pk
- A03: 0 - 250um (10mil) pk-pk
- A04: 0 - 630um (25mil) pk-pk
- A05: 0 - 125um (5.0mil) pk-pk

#### **EXX: Probe and Cable (not included)**

- E00\*: TM0180, 8mm Probe, 5m Cable
- E01: TM0180, 8mm Probe, 9m Cable
- E02: 3300, 8mm Probe, 5m Cable
- E03: 3300, 8mm Probe, 9m Cable
- E04: 7200, 8mm Probe, 5m Cable
- E05: 7200, 8mm Probe, 9m Cable
- E06: TM0105, 5mm Probe, 5m Cable
- E07: TM0105, 5mm Probe, 9m Cable
- E08: TM0110, 11mm Probe, 5m Cable
- E09: TM0110, 11mm Probe, 9m Cable
- E10: 3300, 11mm Probe, 5m Cable
- E11: 3300, 11mm Probe, 9m Cable
- E12: 7200, 11mm Probe, 5m Cable
- E13: 7200, 11mm Probe, 9m Cable
- E14: 3309 Probe, 5m Cable

E15: 3309 Probe, 7m Cable

#### **GXX: Mount**

G00\*: DIN rail mount

G01: Plate mount

#### **SXX: Approval**

S00\*: CE Mark

TR CU: № TC RU C-US.ГБ05.B.00479

### **TR3101 Accessories**

The TR3101 requires a proximity probe and extension cable to work as a system.

**TM0180:** 8mm probe

**TM0105:** 5mm probe

**TM0110:** 11mm probe

**TM0181:** Extension cable

**TM900:** Power converter

**TM0200:** 3-1/2 digit display unit

**BNC-3:** BNC adaptor for portable data collector





## Installation

### Installation -Mounting the probe

There are two ways for probe's field installation:

- 1) Please mount the probe in axial direction for TR3101 Three-Wire Transmitter for Shaft Vibration monitoring system. Keep the distance between probe tip and shaft about 0.05" (1.25mm). In order to avoid wrong output, please make sure there is enough distance between probe tip and the other metal material which is monitored. The least distance is 0.63" (16mm), please refer to Figure 1. For exact gapping procedure see the section **Set-up Procedure** of chapter **Operation**. When mounting two probes adjacently, the two probes should keep 1" (25 mm) at least as shown in Figure 2.
- 2) Mount probe holder at the side of bearing as shown in figure 3. This method can easily adjust probe gap.

NOTE:

When inserting the probe through the machine case or bearing cap, the signal voltage may vary widely before the proper gap is obtained. Therefore, be sure the gap is within 0.07" (1.8mm) of the target before attempting to set the gap electrically.

Please refer to section **Order information** of chapter **Maintenance**. Do not change the length of the extension cable or delete it, as such action will adversely affect the calibration and linearity.

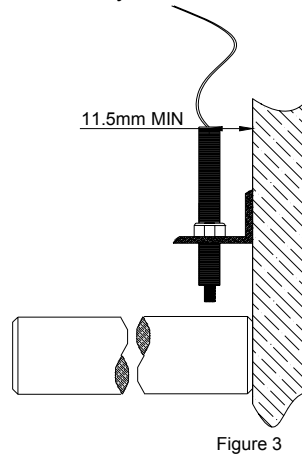
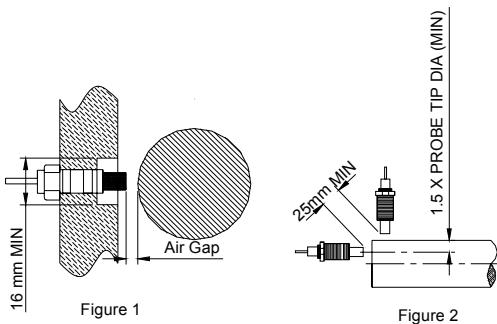

### Mounting the transmitter

The below drawing shows the unit with the optional mounting plate and mounting rail.

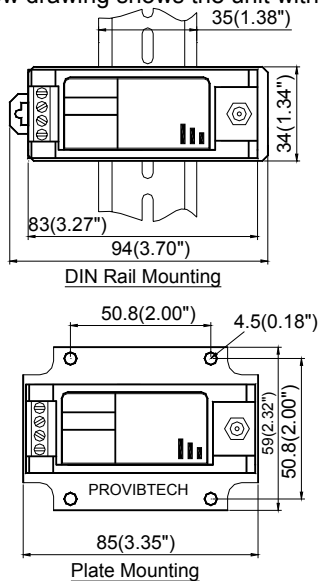



**TR3101 Field-wiring Diagram**

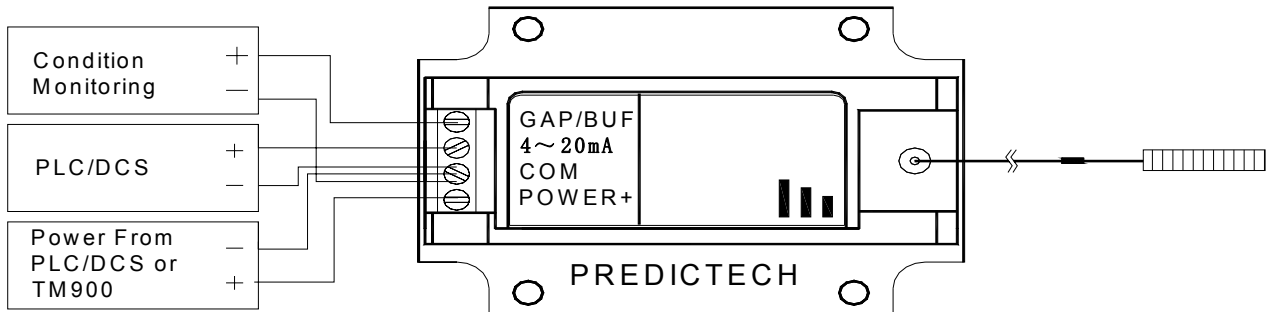



## Operation

### Set-up Procedure – Utilize Voltmeter

- 1) Mount the probe against the shaft.
- 2) Connect the probe, the extension cable, and TR3101.
- 3) Connect the voltmeter to “GAP V” and “COM” on TR3101.
- 4) Turn the power of TR3101 on.
- 5) Gap the probe against the shaft; read the voltmeter until it shows **8V +/- 0.5V**.
- 6) Tighten the probe.

### Power-up Inhibit

During power up, the vibration transmitter will be engaged in the self-test mode. The self-test will test the transducer OK, the vibration transmitter circuitry, and the system functionality. The total time is roughly 5 seconds. After the inhibit time, and the monitor tested OK, the output will be within the 4mA to 20mA range.

### 4mA Calibration Procedure

- 1) Remove the seal of “ZERO” from the top of the transmitter.
- 2) Connect the right probe and extension cable.
- 3) Gap the probe properly (see Field Set-up).
- 4) Connect the transmitter to power and the measuring unit. (Current meter, display unit, PLC/DCS etc.).
- 5) Adjust the potential-meter until the current meter indicates a 4.0mA or a “0” from PLC/DCS.
- 6) Put the seal back.

### Full-Scale Calibration Procedure (for certified Engineer only)

Calibration of full-scale can only be done by experienced (certified) engineer. Special equipments are needed. Please contact with ProvibTech for more details.

- 1) Remove the seal of “ZERO” from the top of the transmitter.
- 2) Remove the top label.
- 3) Connect the TR transmitter, extension cable and eddy probe. Mounting the probe to the shaker, gap the eddy-probe to until the gap voltage shows 8V+/-0.1V.
- 4) With the shaker standstill, turn the “ZERO” potential-meter until the 4-20mA output indicates 4.0mA.
- 5) Turn the shaker to the full-scale vibration. Turn the “SPAN” potential-meter until the 4-20mA output indicates 20.0mA.
- 6) Repeat procedure 4) and 5) four times.
- 7) Put the label and the seal back to the transmitter.

### CAUTION

**The 4-20mA output has been factory calibrated before the shipment. Unless you are sure you understand the conversion factor, and you have the special tools, otherwise, please do not try to calibrate it.**

### Buffered Output / GAP V

Buffered output will directly interface with any diagnostics or condition monitoring equipment. The buffered output will have the same unit as the overall vibration output.



## *Proximity Transmitters, and Seismic Vibration Transmitters*

### CAUTION

- 1) It is not recommended that the diagnostics instrument be directly connected with the buffered output in the middle of the operation. This will likely be engaged in the ground loop problem and will possibly generate false vibration signal.
- 2) If you insist to connect the instrument to the buffered output during the machine operation, you must isolate the instrument from ground. In another word, you must make sure the diagnostics instrument and the Vibration transmitter only has one ground.





## **Maintenance**

TR3101 is a high integrated vibration transmitter. The maintenance described here covers the test of the module and check whether it works properly and primary setting for measuring value.

This part describes vortex probe system monitoring and output current calibration.

Periodic maintenance

Tool preparations

Current calibrating

Exceptional module treatment

### **Periodic Maintenance**

This maintenance interval is very important for the module maintenance. Usually, a yearly maintenance is sufficient. If TR3101 works in extraordinary circumstance, user should shorten the interval according to the actual situation.

### **Extraordinary circumstance**

Used to monitor some critical equipment

High temperature, high humidity, and corrosive environment

### **Maintenance tools**

Multimeter

Screw driver

### **4mA Calibration Procedure**

- 1) Remove the seal of "ZERO" from the top of the transmitter.
- 2) Connect the right probe and extension cable.
- 3) Gap the probe properly (see Field Set-up).
- 4) Connect the transmitter to power and the measuring unit. (Current meter, display unit, PLC/DCS etc.).
- 5) Adjust the potential-meter until the current meter indicates a 4.0mA or a "0" from PLC/DCS.
- 6) Put the seal back.

#### **CAUTION**

**The 4-20mA output has been factory calibrated before the shipment. Unless you are sure you understand the conversion factor, and you have the special tools, otherwise, please do not try to calibrate it.**

### **Exceptional Module Treatment**

In case of finding some exceptions after the test, except the linearity problem which can be solved by calibrating, users should not repair it by themselves. Users could substitute it with a spare TR3101 transmitter and contact with a ProvibTech local office.



**Trouble shooting**

1. NOT OK: The 4-20mA output will be less than 3.0mA if the following condition meet:
  - 1) Probe failure.
  - 2) Extension cable failure.
  - 3) Probe and extension cable are not connected to TR transmitter.
  - 4) Transmitter failure.
  - 5) Probe is not gapped in its linear range.



## TR3102 Three-Wire Transmitter for Thrust Position

### Introduction

#### Condition Monitoring

Measuring rotor thrust position.

#### Machine Type

All kinds of rotation machines with sleeve bearing. Such as blower, compressor, pump, gearbox, and power generators etc.

#### Output

- ✓ 4-20mA.
- ✓ Buffered Output, interface with portable/on-line data collector.
- ✓ System powered by DCS/PLC or TM900.

#### DCS/PLC Interface

Due to the fact that transmitter does not supply alarm function, the PLC or DCS should be configured with some recommendation for alarming and vibration monitoring as follows:

- ✓ **Bypass on start-up:** Some machine will have large vibration on start-up, especially while passing the machine harmonic speed, sometimes, it is recommended to have a bypass on alarm during start-up.
- ✓ **Alarm timed-defeat:** For reliable alarming of machine vibration, you must eliminate the interference due to radio, electric-static discharge etc. API670 normally requires a timed-defeat. The delay time is normally between 1 to 6 seconds that will be determined by field condition.
- ✓ **System self-test:** If there is a defect on probe, extension cable or the transmitter, the 4-20mA will give a current which less than 3.75mA. In this situation, alarm should be disabled.

### Specifications

#### Electrical

DCS or PLC Power Supply:

20-30VDC

Sensor Interface:

Connection:

Special 95Ω coaxial cable with connector

Probe:

5 meter or 9 meter proximity probe and extension cable works with 5mm, 8mm, and 11mm probes



Proximity probe includes: TM0180, TM0105, TM0110, 3300, 7200, 990 series.

Sensor Linear Range (reference with AISI 4140 steel):

5mm, 8mm probe: 2.0 mm (80mil)

Approximately 0.25mm (10mil) to 2.25mm (90mil)

11mm probe: 4.0mm (160mil)

Approximately 0.4mm (15mil) to 4.4mm (175mil)

4-20mA Transmission:

2-wire, source

Buffered Output (GAP V):

Raw position signal

Nominal 2-18VDC

Impedance: 100Ω

Maximum cable distance: 300m (1,000ft)

Sensitivity: 8.0mV/um (200mV/mil) nominal

Frequency response: 0 - 10 KHz

Maximum Load:

500Ω

System Self-test:

System OK: output 4-20mA

System Not OK: output < 3.0mA

#### Physical

Height: 75mm (2.95")

Weight: 1.0kg (2.0 lbs)

#### Environmental

Temperature:

Operation: -40°C to +70°C

Storage: -40°C to +100°C

Humidity:

90% non-condensing

#### Order Information

\* Factory default

Standard configuration:

**TR3102-E00-G00-S00**



## *Proximity Transmitters, and Seismic Vibration Transmitters*

8mm probe:

**TM0180-07-00-05-10-02**

Extension cable:

**TM0181-040-000**

### **TR3102-EXX-GXX-SXX**

#### **EXX: Probe and Cable (not included)**

- E00\*: TM0180, 8mm Probe, 5m Cable
- E01: TM0180, 8mm Probe, 9m Cable
- E02: 3300, 8mm Probe, 5m Cable
- E03: 3300, 8mm Probe, 9m Cable
- E04: 7200, 8mm Probe, 5m Cable
- E05: 7200, 8mm Probe, 9m Cable
- E06: TM0105, 5mm Probe, 5m Cable
- E07: TM0105, 5mm Probe, 9m Cable
- E08: TM0110, 11mm Probe, 5m Cable
- E09: TM0110, 11mm Probe, 9m Cable
- E10: 3300, 11mm Probe, 5m Cable
- E11: 3300, 11mm Probe, 9m Cable
- E12: 7200, 11mm Probe, 5m Cable
- E13: 7200, 11mm Probe, 9m Cable
- E14: 3309 Probe, 5m Cable
- E15: 3309 Probe, 7m Cable

#### **GXX: Mount/ Function**

G00: DIN rail mount, measure position

G01: Plate mount, measure position

#### **SXX: Approval**

S00\*: CE

TR CU: № TC RU C-US.FE05.B.00479

### **TR3102 Accessories**

The TR3102 works with a proximity probe and extension cable.

**TM0180:** 8mm probe

**TM0105:** 5mm probe

**TM0110:** 11mm probe

**TM0181:** Extension cable

**TM900:** Power converter

**TM0200:** 3-1/2 digit display unit

**BNC-3:** BNC adaptor for portable data collector





## Installation

### Installation - Mounting the probe

There are two ways for probe's field installation:

- 1) Please mount the probe in axial direction for TR3102 Three-Wire Transmitter for Thrust Position monitoring system. Keep the distance between probe tip and shaft about 0.05" (1.25mm). In order to avoid wrong output, please make sure there is enough distance between probe tip and the other metal material which is monitored. The least distance is 0.63" (16mm), please refer to Figure 1. For exact gapping procedure see the section **Set-up Procedure** of chapter **Operation**. When mounting two probes adjacently, the two probes should keep 1" (25 mm) at least as shown in Figure 2.
- 2) Mount probe holder at the side of bearing as shown in figure 3. This method can easily adjust probe gap.

#### NOTE:

When inserting the probe through the machine case or bearing cap, the signal voltage may vary widely before the proper gap is obtained. Therefore, be sure the gap is within .07" (1.8mm) of the target before attempting to set the gap electrically.

Please refer to section **Order information** of chapter **Maintenance**. Do not change the length of the extension cable or delete it, as such action will adversely affect the calibration and linearity.

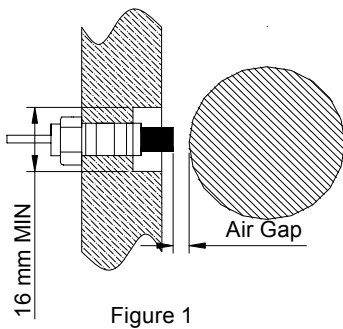

Figure 1

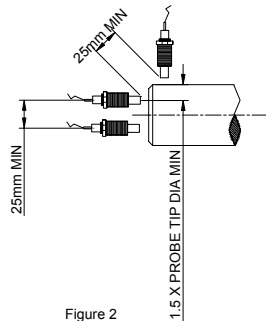

Figure 2

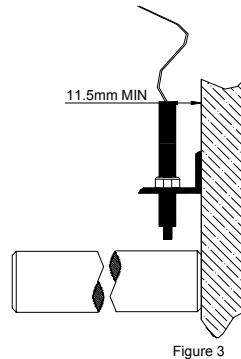
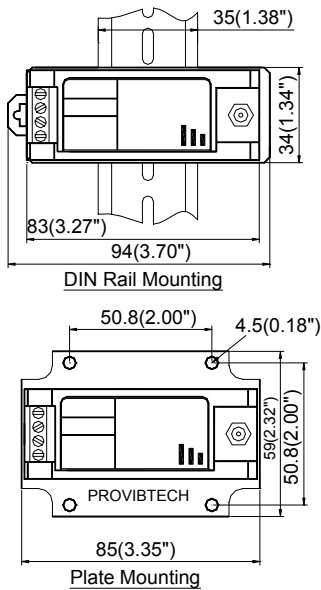

Figure 3

### Installation - Mounting the transmitter

The below drawing shows the unit with the optional mounting plate and mounting rail.





*Proximity Transmitters, and Seismic Vibration Transmitters*

**Installation - TR3102 Field-wiring Diagram**

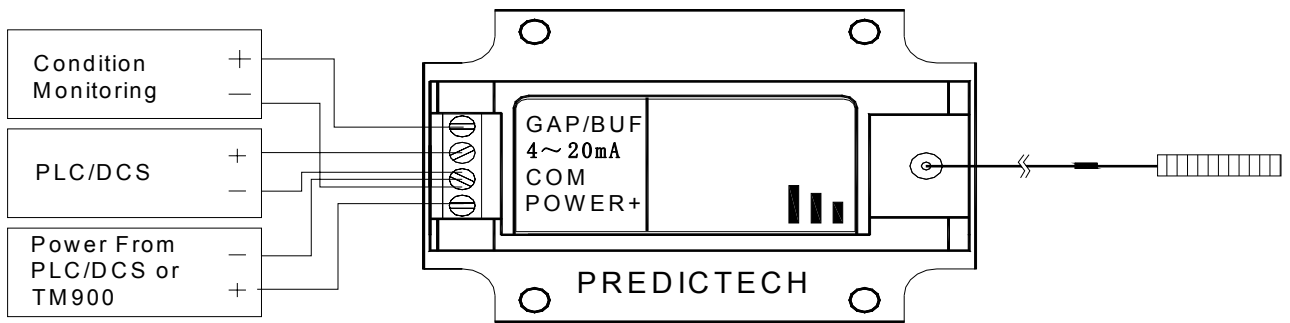



### Operation

#### Power-up Inhibit

During power up, the transmitter will be engaged in the self-test mode. The self-test will test the proximity probe system, the transmitter circuitry, and the system functionality. The total time is roughly 5 seconds. After the inhibit time, and the monitor tested OK, the output will be within the 4mA to 20mA range

#### Set-up Procedure – Utilize Voltmeter

- 1) Mount the probe against the shaft.
- 2) Connect the probe, the extension cable, and the TR3102.
- 3) Connect the voltmeter to GAP V and COM on TR3102.
- 4) Turn the power of TR3102 on.
- 5) Gap the probe against the shaft; read the voltmeter until it shows **10V +/- 0.25V**.
- 6) Tighten the probe.

#### 4-20mA Calibration Procedure (for certified Engineer only)

Calibration of 4-20mA can only be done by experienced (certified) engineer. Special equipments are needed. Please contact with ProvibTech for more details.

- 1) Remove the seal of “ZERO” and “SPAN” from the top of the transmitter.
- 2) Connect the TR transmitter, extension cable and eddy probe. Mounting the probe to the static calibrator, gap the eddy-probe to until the gap voltage shows 10V. This is the center of the linear range. Note this “central gap”.
- 3) Turn the static-calibrator 1.0mm toward the probe tip from the “central gap”. Adjust the “ZERO” potential-meter until the 4-20mA output indicates 4.0mA.
- 4) Turn the static-calibrator 1.0mm away from the probe tip from the “central gap”. Adjust the “SPAN” potential-meter until the 4-20mA output indicates 20.0mA.
- 5) Repeat procedure 3) and 4) four times.
- 6) Put the seals back to the transmitter.

#### CAUTION

**The 4-20mA output has been factory calibrated before the shipment. Unless you are sure you understand the conversion factor, and you have the special tools, otherwise, please do not try to calibrate it.**

#### Buffered Output / GAP V

Buffered output will directly interface with any diagnostics or condition monitoring equipment. The buffered output will have the same unit as the overall vibration output.

#### CAUTION

- 1) **It is not recommended that the diagnostics instrument been directly connected with the buffered output in the middle of the operation. This will likely been engaged in the ground loop problem and will possibly generate false vibration signal.**
- 2) **If you insist to connect the instrument to the buffered output during the machine operation, you must isolate the instrument from ground. In another word, you must make sure the diagnostics instrument and the Vibration transmitter only has one ground.**



## **Maintenance**

TR3102 is a high integrated Thrust Position transmitter. The maintenance described here covers the test of the module and check whether it works properly and primary setting for measuring value.

This part describes vortex probe system monitoring and output current calibration.

Periodic maintenance

Tool preparations

Current calibrating

Exceptional module treatment

### **Periodic Maintenance**

This maintenance interval is very important for the module maintenance. Usually, a yearly maintenance is sufficient. If TR3102 works in extraordinary circumstance, user should shorten the interval according to the actual situation.

### **Extraordinary circumstance**

Used to monitor some critical equipment

High temperature, high humidity, and corrosive environment

### **Maintenance tools**

Multimeter

Screw driver

### **4-20mA Calibration Procedure (for certified Engineer only)**

Calibration of 4-20mA can only be done by experienced (certified) engineer. Special equipments are needed. Please contact with ProvibTech for more details.

- 1) Remove the seal of "ZERO" and "SPAN" from the top of the transmitter.
- 2) Connect the TR transmitter, extension cable and eddy probe. Mounting the probe to the static calibrator, gap the eddy-probe to until the gap voltage shows 10V. This is the center of the linear range. Note this "central gap".
- 3) Turn the static-calibrator 1.0mm toward the probe tip from the "central gap". Adjust the "ZERO" potential-meter until the 4-20mA output indicates 4.0mA.
- 4) Turn the static-calibrator 1.0mm away from the probe tip from the "central gap". Adjust the "SPAN" potential-meter until the 4-20mA output indicates 20.0mA.
- 5) Repeat procedure 3) and 4) four times.
- 6) Put the seals back to the transmitter.

### **CAUTION**

**The 4-20mA output has been factory calibrated before the shipment. Unless you are sure you understand the conversion factor, and you have the special tools, otherwise, please do not try to calibrate it.**

### **Exceptional Module Treatment**

In case of finding some exceptions after the test, except the linearity problem which can be solved by calibrating, users should not repair it by themselves. Users could substitute it with a spare TR3102 transmitter and contact with a ProvibTech local office.





**Trouble shooting**

1. NOT OK: The 4-20mA output will be less than 3.0mA if the following condition meet:
  - 1) Probe failure.
  - 2) Extension cable failure.
  - 3) Probe and extension cable are not connected to TR transmitter.
  - 4) Transmitter failure.
  - 5) Probe is not gapped in its linear range.