

Chapter 16

07KR51-HSB

Hot Stand-By functionalities

07KR51-HSB

(blank page)

07KR51-HSB

This chapter wants to describe the general characteristics and operating conditions and rules of the 07KR51-HSB central unit. This 50 series central unit with redundancy firmware can be used in hot stand-by functionalities on CS31.

1.1 Presentation

The 07KR51-HSB is based on the basic 50 series central units. This version of 50 series central unit with redundancy firmware can be used in hot stand-by functionalities on CS31. The meaning is that a hot stand-by remote central unit can handle directly all inputs and outputs on CS31 bus if the hot stand-by master shuts down, without any discontinuity on the process. The hot stand-by remote central unit is only a reading of all inputs on the CS31 bus and it executes its own program without any output assignment. The user program in both central units can be different (for example to implement a shutdown sequence). In case of an error in the hot stand-by master central unit, the hot stand-by remote central unit will take over within a maximum of 3 cycle times.

1.1.1 General set-up rules

In order to assure this functionality, the architecture must have one 07KR51-HSB central unit configured in master hot stand-by, and one slave 07K51-HSB central unit configured in slave remote hot stand-by.

Each 07KR51-HSB central units incorporate a specific number of binary inputs / outputs. And it is possible, to increase this number of binary or analog inputs / outputs, by addition of different extensions directly connect to the 07KR51-HSB central units.

These extensions are the same that used with standard 40 and 50 series central units. (See references inside technical documentation – 1SBC260400R1001)

It is possible to use decentralized inputs / outputs units via the CS31 twisted pair:

- ICMK14F1 or ICMK14N1 remote units + its own basic extensions
- 07KR51 or 07KT51 basic central units configured in slave mode.
- DC551 remote units + its own basic extensions



It is not possible to use the following function blocks (MT_CS31, MR_CS31, ST_CS31 and SR_CS31) under AC31GRAF programming software, to simplify the communication between the 07KR51-HSB master central unit and basic slave central units.



In order to use the S500 remote units DC551 + its own basic extensions, it is necessary to used specific function blocks in order to configure the inputs /outputs parameters.

These function blocks are only available with AC31GRAF programming software.



The cycle time of both the central units, master and slave HSB, have to be set exactly similar for a perfect synchronisation. It is not recommended to load more than 50% of the memory.

07KR51-HSB

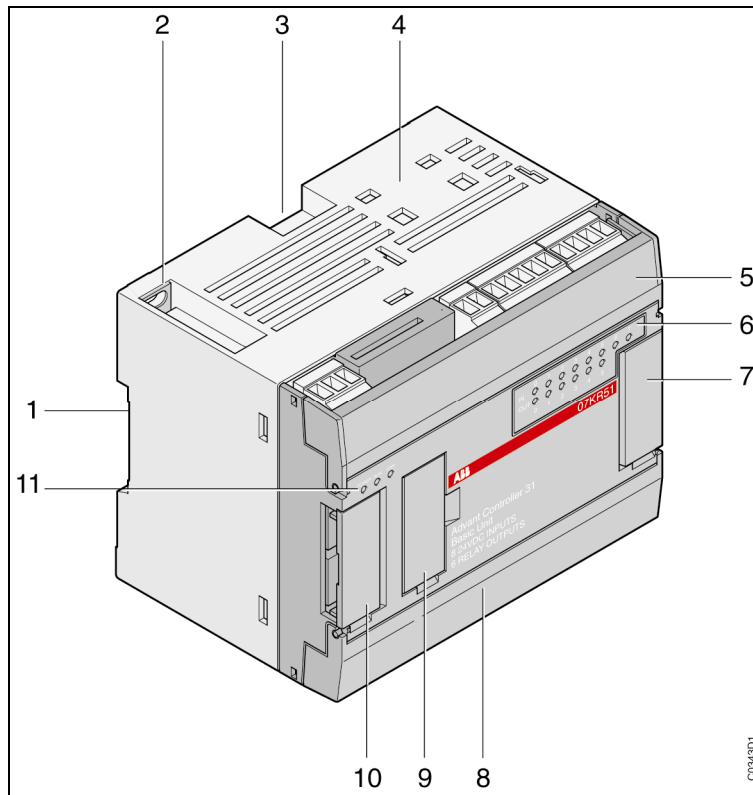

The front of the unit

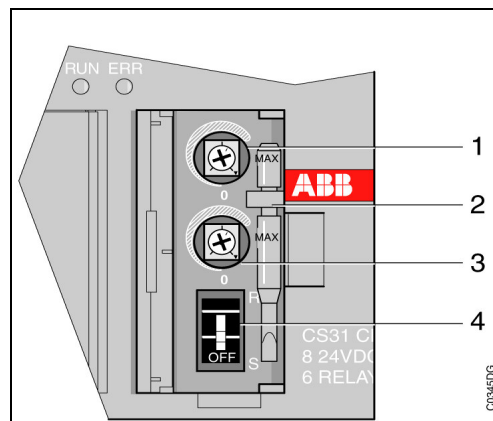

Enlargement of item 9 without cover

07KR51-HSB

1.1.2 The front (see Figure)

- 1 - Location for the DIN rail
- 2 - Plate fixture with unit earthing
- 3 - Lock for DIN rail mounting
- 4 - Location for external dual connector
- 5 - Location for the cabling connectors:
 - of 24 V d.c. output power for the inputs
(available only for the remote units with 120 / 230 V a.c. power)
 - of the inputs
- 6 - Visualization set for the status of the 8 inputs / 6 outputs
- 7 - Location of the connector for the connection of input/output extensions
- 8 - Location of the cabling connectors:
 - the serial port for programming or communication ASCII / MODBUS[®]
 - connector for the central unit power supply cabling
 - connectors for the outputs cabling
- 9 - Location of the addressing rotate selectors (see enlargement)
- 10 - Unit status visualization area:
 - POWER: power on
 - RUN: Blinking indicates the valid message received
 - ERR: On indicates error(s) present and blinking indicates configuration action

Enlargement of item 9 without cover (see Figure)

- 1 - Potentiometer whose value is read into the IW62.01 variable by the program
(value of 0 to 150 in the program)
- 2 - Screwdriver for potentiometer adjustment
- 3 - Potentiometer whose value is read into the IW62.00 variable by the program
(value of 0 to 150 in the program)
- 4 - Central unit program ON/OFF switch

07KR51-HSB

1.2 General operating conditions

The 07KR51-HSB central units were developed according to the European EC directives, the main national and international IEC 1131-1 and IEC 1131-2 standards and the EN61131-2 product standard concerning automation devices.

Ambient conditions - Temperature: operation: horizontal vertical storage transport - Humidity: annual average up to 30 days per year occasionally - Atmospheric pressure: operation storage	0 °C to + 55 °C 0 °C to + 40 °C - 40 °C to + 75 °C - 25 °C to + 75 °C DIN 40040 class F without condensation ≤ 75% 95% 85% DIN 40050 ≥ 800 hPA (≤ 2000 m) ≥ 600 hPA (≤ 3500 m)
Mechanical data - Protection index - Unit - Vibration stress - Shock stress	IP20 UL V2 CEI68-2-6 test Fc CEI68-2-27 test Ea
Tolerances for mains voltages - 24 V d.c. - 120 V a.c. (50 / 60 Hz) - 230 V a.c. (50 / 60 Hz)	19.2 to 30 V (- 20%, + 25%) 97.75 to 126.5 V (- 18,5%, + 5,5%) 195.5 to 253 V (- 15%, + 10%)

07KR51-HSB

Creepage distances and clearances	IEC 664 and DIN VDE0160
Insulation test	IEC 1131-2
Electromagnetic compatibility Immunity tests against: <ul style="list-style-type: none"> - Electrostatic discharge - Radiated fields - Fast transient bursts - High energy pulse - Conducted high frequencies 	IEC 1000-4-2 (level 3) IEC 1000-4-3 (level 3) IEC 1000-4-4 (level 3) IEC 1000-4-5 IEC 1000-4-6 (level 3)
Voltage drops and short power cutoffs <ul style="list-style-type: none"> - D.C. power supply - A.C. power supply 	Duration of the power cutoffs: ≤ 10 ms Time between 2 voltage drops: ≥ 1 s Duration of the power cutoffs: ≤ 20 ms Time between 2 voltage drops: ≥ 1 s
Clearance	IEC 664-664A DIN VDE 0160
Dielectric test	IEC 1131-2
Mountings <ul style="list-style-type: none"> - DIN rail - Screw fittings 	35 mm 4 mm diameter screw (M4)
Connections <ul style="list-style-type: none"> - Connectors - Wires section for: <ul style="list-style-type: none"> Earth Inputs Outputs Power supply Bus - Screws tightening torque 	Removable terminal blocks (2.5 mm ²) Rigid or multi-conductor wire AWG 14 (1.95 mm ²) Rigid or multi-conductor wire AWG 18 (0.96 mm ²) to AWG 14 (1.95 mm ²) Rigid or multi-conductor wire AWG 14 (1.95 mm ²) Rigid or multi-conductor wire AWG 14 (1.95 mm ²) Twisted pair AWG 24 (0.22 mm ²) to AWG 18 (0.8 mm ²) 0.5 Nm (given as an indication only)
Serial interface <ul style="list-style-type: none"> - For programming - For the bus 	RS 232 / RS 485 RS 485

07KR51-HSB

1.3 Technical specifications

Products	Description	References
07KR51 - HSB 24VDC	With 8 isolated inputs 24 V d.c and 6 relay outputs 250 V a.c. / 2A 24 V d.c. power supply.	1SBP260015R1001
07KR51 - HSB 120/230VAC	With 8 isolated inputs 24 V d.c and 6 relay outputs 250 V a.c. / 2A 120 / 230 V a.c. power supply.	1SBP260016R1001

	07KR51-HSB 24 V d.c.	07KR51-HSB 120 / 230 V a.c.
Width x Height x Depth (in mm)	120 x 93 x 84	
Weight	400 g	800 g
Power supply		
- Mains voltage:		
Nominal value	24 V d.c.	120 / 230 V a.c.
Admissible range	19.2 to 30 V	97.75 to 126.5 V 195.5 to 253 V
- Consumption:		
Unit alone (typical)	80 mA	30 mA
Maximum configuration (typical)	400 mA	100 mA
- Polarity reversal protection	yes	-
- 24 V d.c. isolated power for inputs:	no	yes
Range of voltage value	-	19.2 to 30 V
Max. Output current	-	400 mA
Short circuit protection	-	yes
- Dissipation	5 W	10 W
Incorporated binary inputs		
- Number of inputs	8	
- Isolation of the inputs / electronic	1500 V a.c.	
- Input types	PNP and NPN	
- Input voltage:		
Nominal value	24 V d.c.	
Signal at 0 (IEC 1131-2)	0 to + 5 V	
Signal at 1 (IEC 1131-2)	+ 15 to + 30 V	
- Input current at 24 V d.c.:		
Inputs Ixx.02 to Ixx.07	7 mA	
Inputs Ixx.00 and Ixx.01	9 mA	
- Minimum filtering time	5 ms	
- Cable length:		
unshielded	300 m	
shielded	500 m	

07KR51-HSB

	07KR51-HSB 24 V d.c.	07KR51-HSB 120 / 230 V a.c.
Incorporated outputs		
- Number of outputs		6 relays
- Isolation of the outputs / electronic		1500 Vrms 1 min
- Total charging current, under voltage:		.
direct 24 V d.c.		
resistive load / inrush current		2 A / 5 A
L / R = 20 ms		2 A
L / R = 30 ms		1 A
L / R = 40 ms		0.6 A
L / R = 60 ms		0.35 A
alternate 24 to 230 V a.c.		2 A AC-1 0.5 A AC-15
- Total charging current		6 x 2 A
- Minimum cut-off values		10 mA under 12 V d.c.
- Breaking power under 120 V a.c. (contact rating code B300) (UL)		2 A
- Breaking power under 250 V a.c. (contact rating code B300) (UL)		2 A (1.5 A according to UL)
- Number of common		2 (2+4)
- Commutating frequency :		
for resistive loads		< 1 Hz
for inductive loads		< 0.2 Hz
for lamps		< 0.2 Hz
- Number of switches:		
for AC-1		1 million
for AC-15		100 000
- Short circuit and overload protection		envisage externally
- Surge voltage protection		envisage externally
- Cable length:		
unshielded		150 m
shielded		500 m

07KR51-HSB

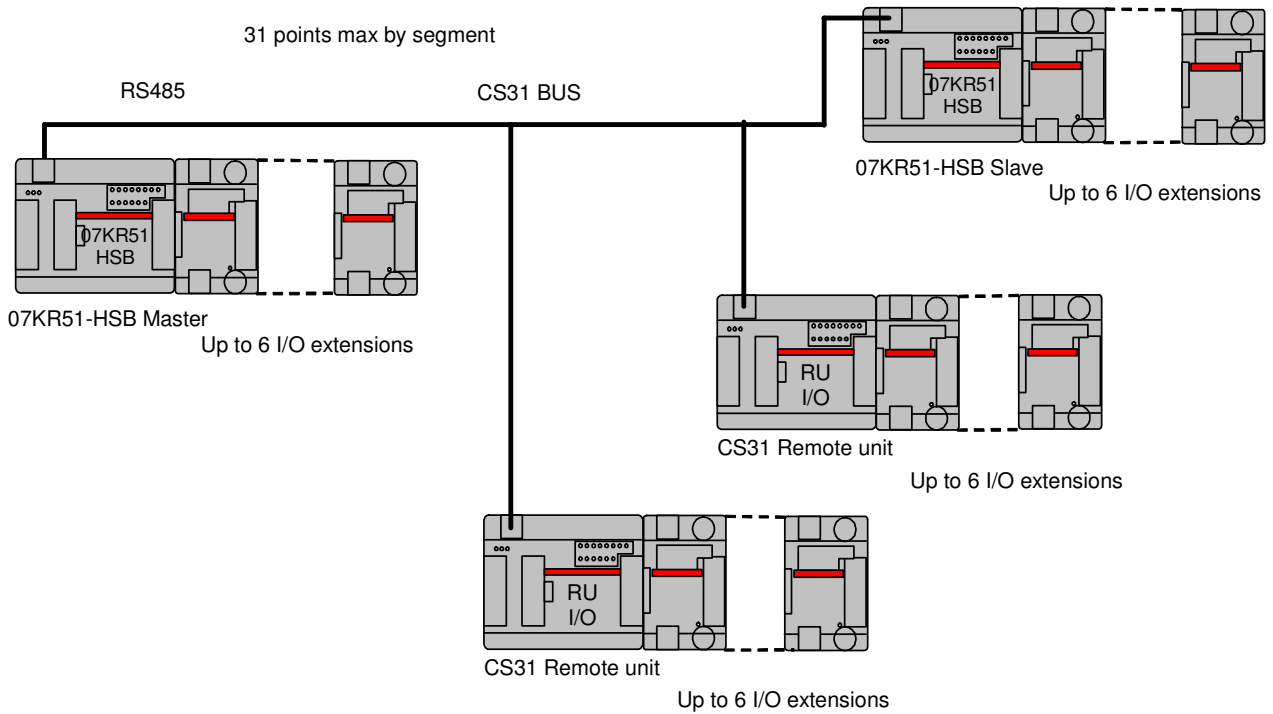

Network with I/O remote units ICMK14F1 or ICMK14N1 + AC31 extension modules.

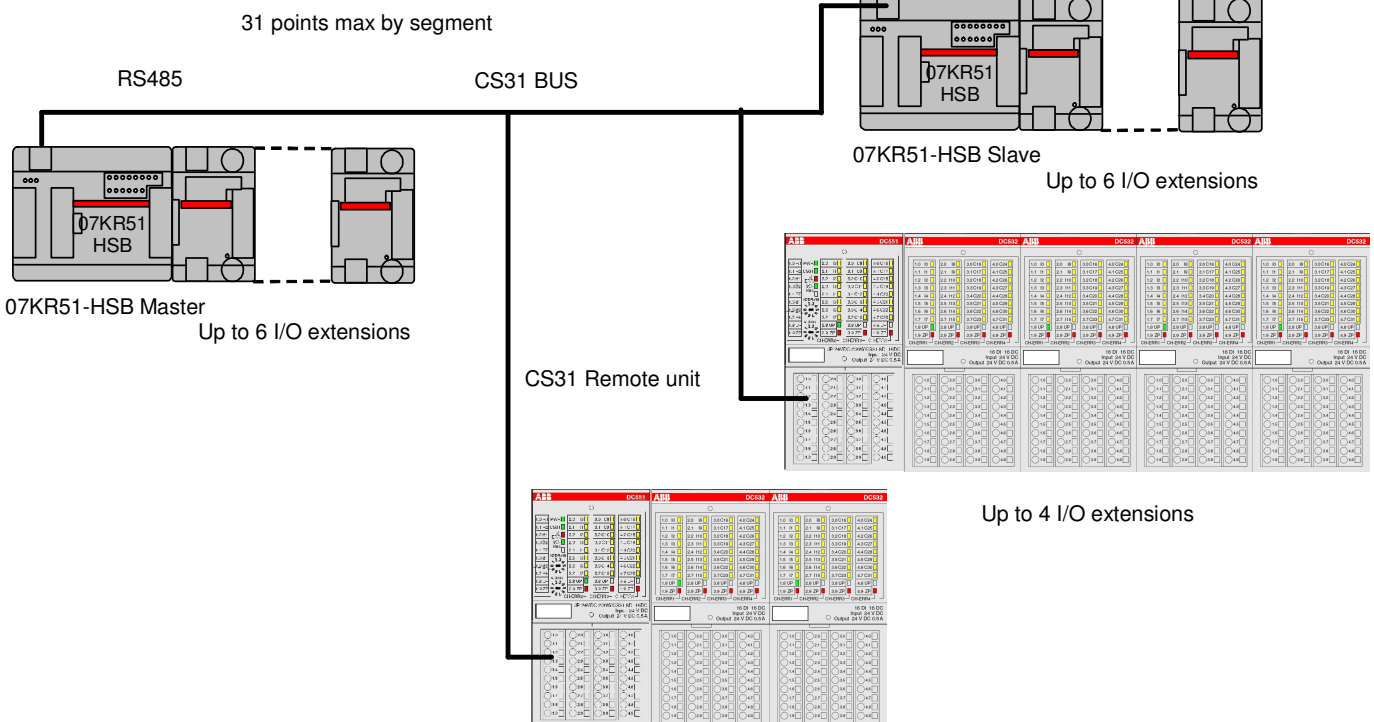

Network with I/O remote units DC551 + S500 extension modules. (See paragraph 1.4.7.4 for CS31 cabling rules)

07KR51-HSB

1.4 Configuration and operation

1.4.1 Introduction

The same 07KR51-HSB central unit can be configured with the three different operative modes, depending to the function wished in the redundant CS31 architecture:

- ⇒ Hot-stand-by master,
- ⇒ Hot stand-by self remote central unit, is able to start alone if hot stand-by master central unit fails on power ON.
- ⇒ Hot stand-by remote central unit, is able to starts only if previously the hot stand-by master central unit has started properly on power ON

The hot stand-by master, and hot stand-by remote central units, as well as the remote units, may be positioned in any order on the bus.

1.4.2 Configuration

Software interface configuration:

Click on the  "Launch PLC configuration tool" icon in the control menu of the AC31GRAF programming software. Then select the hot stand-by configuration from the list of the "Central unit operative mode (CS31 MODBUS® on CS31 bus)" line (see below)

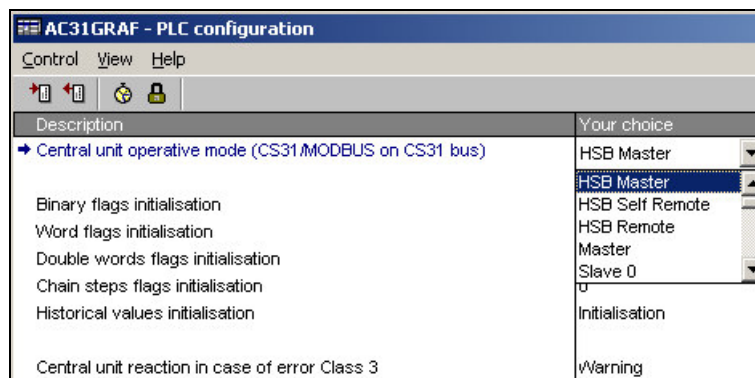

Terminal mode / system constants:

- ⇒ Hot stand-by master central unit => KW00.00 = -5

One hot stand-by central unit has to be defined as master. This central unit will be initialized as a prior central unit and will synchronize the hot stand-by central units, master and remote.

- ⇒ Hot stand-by self remote central unit => KW00.00 = -3

The hot stand-by remote central unit will start the control of CS31 bus after 3-30 seconds if it receives no request from the hot stand-by master central unit. This configuration is recommended if the hot stand-by master central unit can be defective after a power supply ON and if the application has to start.

- ⇒ Hot stand-by remote central unit => KW00.00 = -7

The hot stand-by remote central unit will start the control of CS31 only if the master fails. That means that the hot stand-by master central unit has to be initialized and synchronized the hot stand-by remote central unit. Otherwise the hot stand-by remote central unit will never start the control of CS31 bus.

07KR51-HSB

Internal outputs:

Inside the 07KR51-HSB, several internal outputs exist for the management of redundant functionality. These internal outputs are

- ⇒ **%O62.08:** When the synchronization is realized between hot stand-by central units, master and remote, the bit %O62.08 is set to 1. And if the synchronization is lost, the bit %O62.08 is reset to 0 in both hot stand-by central units.
- ⇒ **%O62.09:** The bit %O62.09 is set to 1 in the hot stand-by central unit, who controls the CS31 bus, master or remote depending on events. In order to know the status of the hot stand-by central units on the CS31 bus
- ⇒ **%O62.10:** The bit %O62.10 is set to 1 when the hot stand-by master central unit is with the system constant setting to -5
- ⇒ **%O62.11:** If the bit %O62.11 is set to 1 by one of the hot stand-by central units, the both hot stand-by central units, master and remote are restarted (like Warm start command). This command is necessary to reset completely the system.
- ⇒ **%O62.12:** The bit %O62.12 is used to reactive the hot stand-by function on the master central unit after one failure. After failure, if the bit %O62.12 is set to 1 the hot stand-by function is enabling and it is waiting for a next failure of the present hot stand-by master central unit to recover again the control of CS31 bus. If the bit %O62.12 is set to 0, the hot stand-by central unit can not be master on CS31 bus.
- ⇒ **%O62.13:** The bit %O62.13 is used to force the hot stand-by central unit to take the control of CS31 bus. If bit %O62.13 is set to 1 and if the bit %O62.10 is at 1, the hot stand-by central unit will take the control of the CS31 bus, and the bit %O62.09 will be set to 1.

Internal input/output words:

Inside the 07KR51-HSB, several internal input/output words exist for the management of data information between the both hot stand-by central units, master and remote. It is possible for example through these internal variables to set the internal parameters from one hot stand-by central unit to the other. These internal input/output words are

- ⇒ %IW63.08 up to %IW63.15 and
- ⇒ %QW63.08 up to %QW63.15

1.4.3 Initialization

The hot stand-by master central unit starts synchronization, sends a frame to hot-stand-by remote central unit, the cycle in hot stand-by remote central unit is adjusted by itself on several cycles times to be synchronized with hot stand-by master central unit. The hot stand-by remote central unit has to be in RUN mode. The synchronization can take some minutes. When the synchronization is done, the bit %O62.08 is set to 1 in the both hot stand-by central units, master and remote, this bit %O62.08 can be used for example in the both hot stand-by central units, master and remote to start program operation, with JUMP function block.



During this synchronization phase, the hot stand-by master central unit executes its own program. The program in both hot stand-by central units, master and remote can be different.



The cycle times in the both hot stand-by central units, master and remote have to exactly set to the same value.



The both hot stand-by central units, master and remote read all digital and analog inputs from CS31 bus in the same cycle time. Only the central unit, who controls the CS31 bus, assigns the digital and analog outputs on the CS31 bus. The outputs in the other hot stand-by central unit are only assigned as internal variables.

07KR51-HSB

1.4.4 Diagnosis & functions

All diagnosis on CS31 bus are available on the both hot stand-by central units, master and remote like remote unit disconnected, short circuit outputs, etc...

If the hot stand-by remote central unit does not any traffic on the CS31 bus during one cycle time, the hot stand-by functions start. That means that the hot stand-by remote central unit starts control of inputs/outputs on CS31 bus, reset the bit %O62.08 to 0 and set the bit %O62.09 to 1 and assigns the outputs on CS31 bus according to the current result of the present program.

In case of an error in the hot stand-by master central unit, the hot stand-by remote central unit will take over within a maximum of 3 cycle times. That means that the inputs in the hot stand-by remote central unit will remain with the same value during three cycle times before being refreshed.

If the part of program in the both hot stand-by central units, master and remote who manage the outputs on CS31 are different, it could happen a discontinuity in the status of outputs.

In case of conflict, like two masters on CS31 bus, the hot stand-by central unit configured previously in remote will be switch in hot stand-by remote central unit even if it is in master operation.

If the central unit master goes in STOP mode, the CS31 bus outputs are reset to 0. And the hot stand-by function is not activated. The bit %O62.08 is reset to 0 in the both hot stand-by central units, master and remote.

If the central unit master is again in RUN mode, the bit %O62.08 is reset to 1 in the both hot stand-by central units, master and remote and the cycle times are synchronized but values of variables in the both hot stand-by central units, master and remote can be different.

If the hot stand-by remote central unit does not any traffic on the CS31 bus during one cycle time, the hot stand-by functions start. That means that the hot stand-by remote central unit starts control of inputs/outputs on CS31 bus, reset the bit %O62.08 to 0 and set the bit %O62.09 to 1 and assigns the outputs on CS31 bus according to the current result of the present program. If the part of program in the both hot stand-by central units, master and remote who manage the outputs on CS31 are different, it could happen a discontinuity in the status of outputs.

07KR51-HSB

1.4.5 Synthesis hot stand-by table

Action	07KR51-HSB	Reaction	Action	07KR51-HSB	reaction
Power ON + RUN mode	HSB Master %KW00.00 - %MW3000.0 = -5 %O62.10 - %QX62.10 = 1	Init + Start program + Bus CS31	Power ON + RUN mode	HSB Remote %KW00.00 - %MW3000.0 = -7	Wait master init = ok
	HSB Master %KW00.00 - %MW3000.0 = -5 %O62.08 - %QX62.08 = 1 %O62.09 - %QX62.09 = 1 %O62.10 - %QX62.10 = 1 1) read the inputs 2) write the outputs (binary and analog) 3) diagnosis available 4) exchange words between both CPUs %IW63.08 - %IW1063.08 to %IW63.15 - %IW1063.15 %QW63.08 - %QW1063.08 to %QW63.15 - %QW1063.15	Launch auto synchronization Synchro =ok O62.08=1 Start program + Bus CS31		HSB Remote %KW00.00 - %MW3000.0 = -7 %O62.08 - %OX62.08 = 1 %O62.09 - %QX62.09 = 0 %O62.10 - %QX62.10 = 0 1) read the inputs 2) no write the outputs 3) diagnosis available 4) exchange words between both CPUs %IW63.08 - %IW1063.08 to %IW63.15 - %IW1063.15 %QW63.08 - %QW1063.08 to %QW63.15 - %QW1063.15	Launch auto synchronization Synchro =ok O62.08=1 Start program
Option 1 Power OFF Or Failure CPU Or CS31 Bus disconnected master side	HSB Master -----	-----	Option 1	HSB Remote %KW00.00 - %MW3000.0 = -7 %O62.08 - %OX62.08 = 0 %O62.09 - %QX62.09 = 1 %O62.10 - %QX62.10 = 0 1) read the inputs 2) write the outputs (binary and analog) 3) diagnosis available 4) exchange words between both CPUs No longer available	Lost synchro Synchro =nok O62.08=0 Start CS31 control CS31 Bus =ok O62.09=1
Option 2 CS31 Bus disconnected between CPUs	HSB Master %KW00.00 - %MW3000.0 = -5 %O62.08 - %QX62.08 = 0 %O62.09 - %QX62.09 = 1 %O62.10 - %QX62.10 = 1 1) read only inputs seen =0 in the other 2) write outputs seen (binary and analog) 3) diagnosis available 4) exchange words between both CPUs No longer available.	Lost synchro Synchro =nok O62.08=0 + red led fixed Start CS31 control part seen CS31 Bus =ok O62.09=1	Option 2 CS31 Bus disconnected between CPUs	HSB Remote %KW00.00 - %MW3000.0 = -7 %O62.08 - %OX62.08 = 0 %O62.09 - %QX62.09 = 1 %O62.10 - %QX62.10 = 0 1) read only inputs seen =0 in the other 2) write outputs seen (binary and analog) 3) diagnosis available 4) exchange words between both CPUs No longer available.	Lost synchro Synchro =nok O62.08=0 + red led fixed Start CS31 control part seen CS31 Bus =ok O62.09=1

07KR51-HSB

1.4.6 The hot stand-by functions with S500 I/O devices

It is also possible to use with the 07KR51-HSB central units, the S500 input/output devices. When these remotes units are used, it will be necessary to implement in the program of the both hot stand-by central units, master and remote, some specific functions to configure them. The type and the number of these specific functions will depend to S500 input/output devices present on CS31 bus.

The specific function blocks are used to send the configuration parameters of the S500 input/output devices, for each device, two specific function blocks exist, one to send the default settings and another to send customer settings. The specific function block to send the configuration parameters with default settings is called with module name +S (Short) i.e. DC532S.

The specific function block S500CONF has to be always implemented in program. One S500CONF function block must be used by DC551 - CS31 bus module presents on CS31 bus or called several times.

The specific function blocks used to configure the modules must match the hard configuration, in term of number and order on DC551 - CS31 bus module.

All these specific function blocks must be used only during the first PLC cycles.

These specific function blocks must be imported to AC31GRAF programming software library.

S500CONF	This function block is used to send the configuration to DC551 - CS31 bus module. One S500CONF function block must be used by DC551 - CS31 bus module presents on CS31 bus.
DC551S	This function block is used to configure the parameters of the DC551 - CS31 bus module with default settings.
DC551	This function block is used to configure the parameters of the DC551 - CS31 bus module with customer settings.
DC551FCS	This function block is used to configure the parameters of the DC551 - CS31 bus module + fast counter option with default settings.
DC551FC	This function block is used to configure the parameters of the DC551 - CS31 bus module + fast counter option with customer settings.
DI524S	This function block is used to configure the parameters of the DI524 - Digital input module with default settings.
DI524	This function block is used to configure the parameters of the DI524 - Digital input module with customer settings.
DC522S	This function block is used to configure the parameters of the DC522 - Digital input/output module with default settings.
DC522	This function block is used to configure the parameters of the DC522 - Digital input/output module with customer settings.
DC523S	This function block is used to configure the parameters of the DC523 - Digital input/output module with default settings.
DC523	This function block is used to configure the parameters of the DC523 - Digital input/output module with customer settings.
DC532S	This function block is used to configure the parameters of the DC532 - Digital input/output module with default settings.
DC532	This function block is used to configure the parameters of the DC532 - Digital input/output module with customer settings.
DX522S	This function block is used to configure the parameters of the DX522 - Digital input/output module with default settings.
DX522	This function block is used to configure the parameters of the DX522 - Digital input/output module with customer settings.
DX531S	This function block is used to configure the parameters of the DX531 - Digital input/output module with default settings.

07KR51-HSB

DX531	This function block is used to configure the parameters of the DX531 - Digital input/output module with customer settings.
AI523S	This function block is used to configure the parameters of the AI523 - Analog input module with default settings.
AI523	This function block is used to configure the parameters of the AI523 - Analog input module with customer settings.
AX521S	This function block is used to configure the parameters of the AX521 - Analog input/output module with default settings.
AX521	This function block is used to configure the parameters of the AX521 - Analog input/output module with customer settings.
AX522S	This function block is used to configure the parameters of the AX522 - Analog input/output module with default settings.
AX522	This function block is used to configure the parameters of the AX522 - Analog input/output module with customer settings.
AO523S	This function block is used to configure the parameters of the AO523 - Analog output module with default settings.
AO523	This function block is used to configure the parameters of the AO523 - Analog output module with customer settings.

In progress.....Programming and configuration example with AC31GRAF...

07KR51-HSB

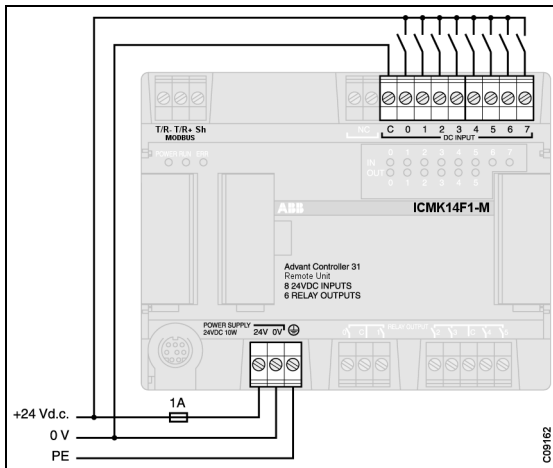

Figure: Positive logical inputs PNP 24 V d.c. unit power supply

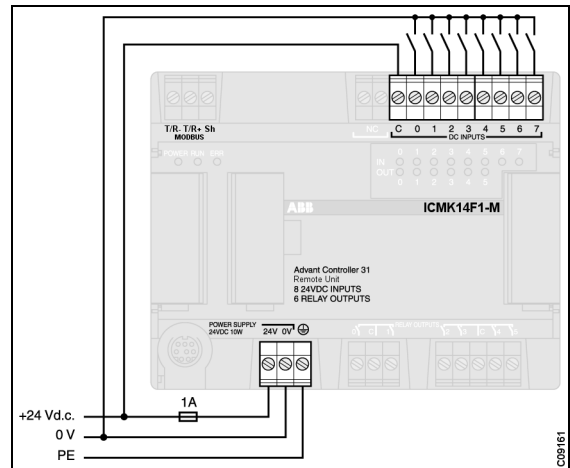

Figure: Negative logical inputs NPN 24 V d.c. unit power supply

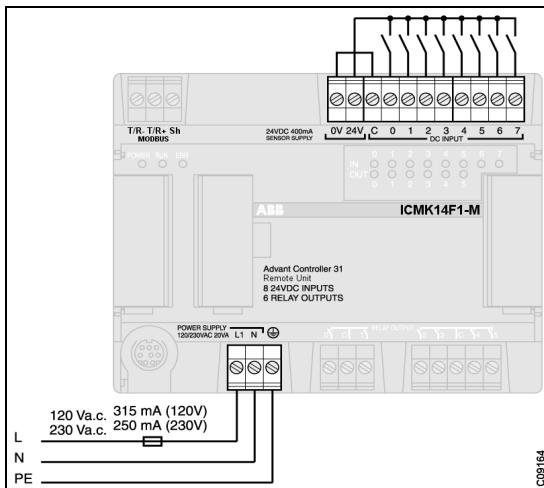

Figure: Positive logical inputs PNP 120/230 V a.c. unit power supply

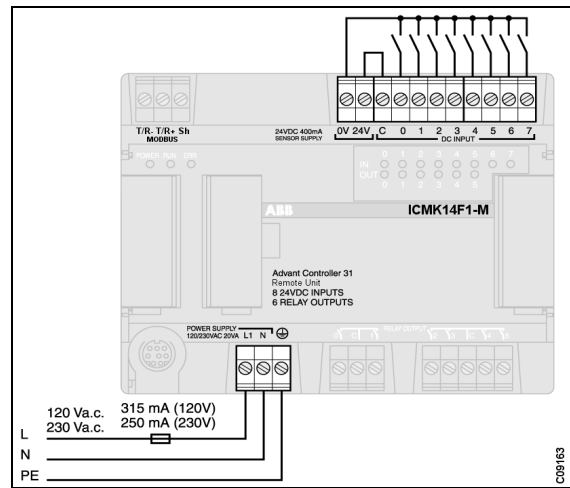

Figure: Negative logical inputs NPN 120/230 V a.c. unit power supply

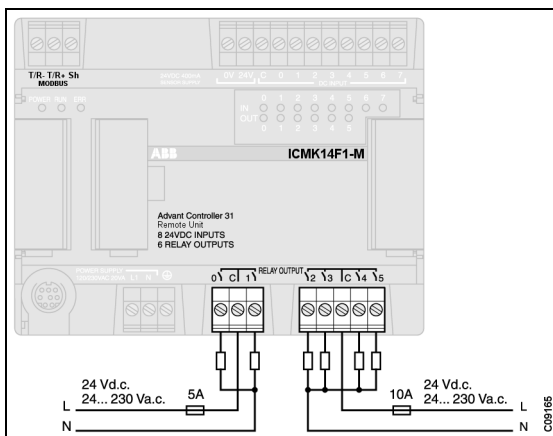

Figure: Relay outputs

07KR51-HSB

1.4.7 Installation

The 07KR51-HSB products have been conceived for operation in extreme industrial environments. The correct operation of these products is only ensured if all EMC protection rules have been applied.

(see technical documentation 1SBC260400R1001 chapter 4) Assembly conditions

The 07KR51-HSB must be mounted on a DIN rail (35 mm) by using the support lock . It may be installed vertically or horizontally.

For a cabinet assembly:

Operating temperature from 0 to 55°C, envisage sufficient free volume around the units to allow the heat to dissipate correctly. It is recommended that the cabinet is fitted with a ventilation system.

Warning avoid placing heat generating devices next to the products (transformers, mains, power contactors, ...).

All electrical connections are realized through removable terminal blocks with an acceptable wire section equal to 2.5 mm².

The tightening torque, for reference, is equal to 0.5 Nm.

In order to guaranty the safety and error free data transmission over long distances, the selection of an appropriate communication cable is very important.

1.4.7.1 Power supply

Use rigid or multi-conductor AWG 14 (1.95 mm²) wires.

The connection of an external thermal fuse is necessary to provides material protection.

It is possible to select 230 V a.c. or 120 V a.c. with the selector switch situated underneath the central units or extensible remote units. The products are delivered with the selector in the 230 V a.c. position.

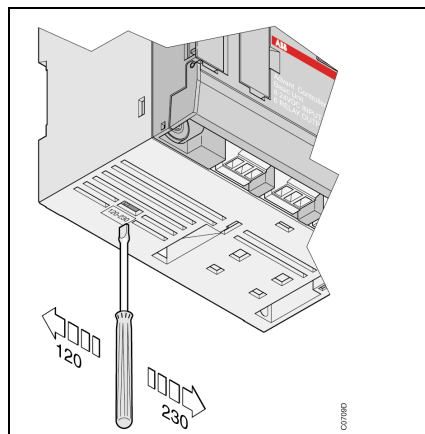

An internal 24 V d.c. power supply is available on 120 / 230 V a.c. versions. This power supply feeds the binary inputs of the unit and its extensions This internal power supply is protected against short circuits and overloads. In the case of a short circuit or overload it is available 10 seconds after the fault elimination.

It is also possible to use an external 24 V d.c. power supply. In this case do not forget to connect the earth of the external 24 V d.c. to that common to the inputs (terminal C).

07KR51-HSB

1.4.7.2 Inputs/outputs cabling

Use rigid or multi-conductor AWG 18 (0.96 mm²) to AWG 14 (1.95 mm²) wires for inputs and the rigid or multi-conductor AWG 14 (1.95 mm²) wires for the outputs.

- Input cabling: see Figure to Figure. The common C of inputs has to be linked to the 0 V or 24 V d.c. according to the sensor type.
- Output cabling: see Figure and **Erreur ! Source du renvoi introuvable..**

1.4.7.3 Output protection

The relay outputs may be protected externally against parasites generated by an inductive load with:

- a varistor or an RC module, in alternating current
- a free-wheel diode, in direct current

The presence of an external thermal fuse, connected to the common power supply of the outputs, protects to the output connected devices.

1.4.7.4 Cabling of the CS 31 bus

The CS 31 bus is a RS 485 serial interface and consists of a shielded twisted pair. This bus is a master slave bus and only accepts a single master.

Use a AWG 24 (0.22 mm²) to AWG 18 (0.18 mm²) twisted pair.

The maximum length is 500 m.

The same cable type should be used for the whole system bus setup.

Bus interruptions should be avoided, during cabinet cable connections for instance, otherwise it should be cabled to the same side of the terminal block



Warning: STAR connection of the bus is not permitted!

The central and remote units may be connected at any point of the bus:

- bus 1 on bus 1
- bus 2 on bus 2
- shielding (preferably braided) on terminal 3 of terminal block 1 and earth connected at the master level (cable < 1 m)

The bus should be terminated with a 120 Ω 1/4 W resistance connected to the bus extremities. The twisted pair should be symmetrical

07KR51-HSB

Overview of electrical isolations

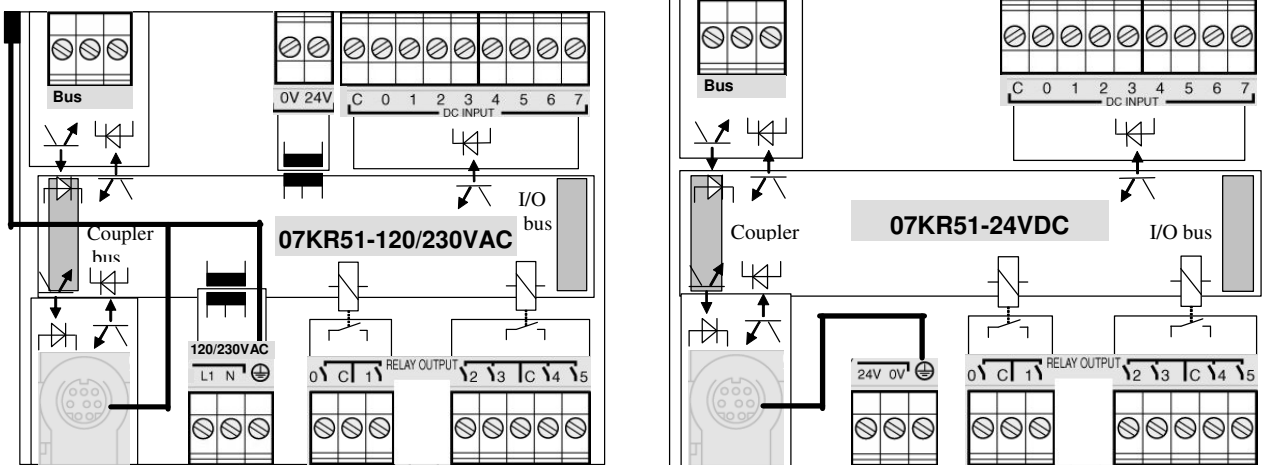

1.5 Dimensions (in mm)

1.5.1 07KR51-HSB central unit

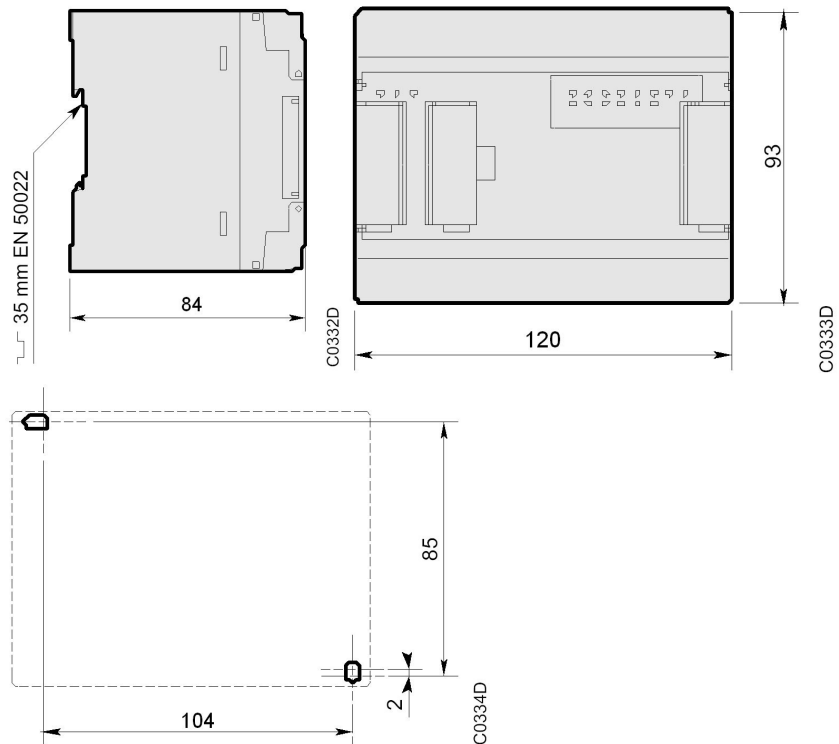

07KR51-HSB

(blank page)