

SAO-0220m

Safe analog output module (0(4)—20 mA, 2 channels)

Description

The safe analog output module SAO-0220m has two 0(4)—20 mA output channels for analog control applications. The load may only be resistive or capacitive. Inductive loads will cause the analog output module to be reported faulty. The two analog outputs are galvanically isolated from the 24 Vdc and the 5 Vdc. The 0 V 1 (d14) pin and 0 V 2 (d20) pin are interconnected on the module.

Each analog output channel consists of a 12-bit D/A converter for the output value and an A/D converter which reads the output value. By using the A/D converter, it is possible to check the correct functioning of the output channel.

Within the configured Diagnostic Test Interval, the analog outputs are tested for:

- Correct output value (current value $\pm 5\%$)
- Ability to de-energize
- Cross talk between analog outputs

Each analog output has a secondary means of de-energizing (SMOD). This enables the watchdog and the processor to de-energize the outputs, irrespective of the result of the application value.

Figure 210 Schematic diagram for connection of the SAO-0220m module as an active output

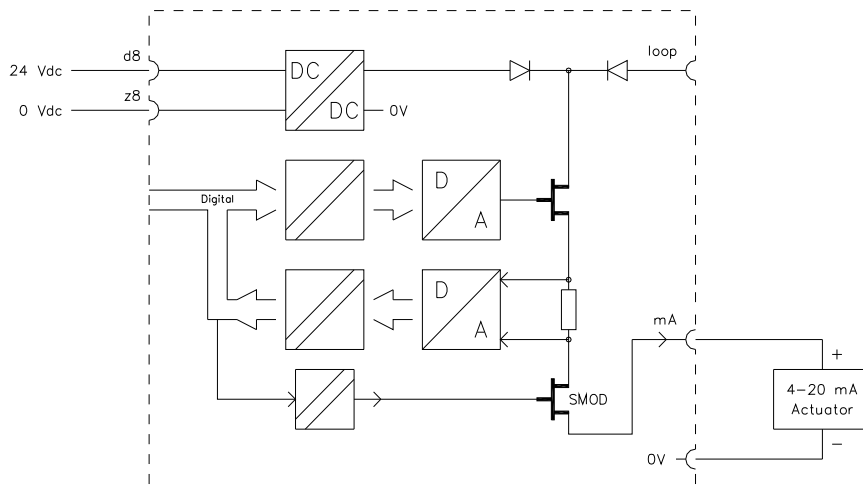
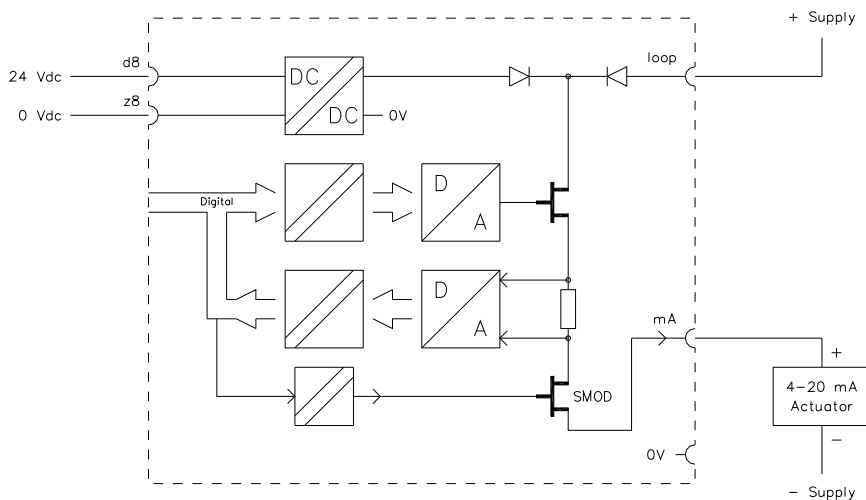

Figure 211 Schematic diagram for connection of the SAO-0220m module as a passive output



Redundant analog out

As of release 120 of Safety Builder, Safety Manager supports redundant analog outputs.



Attention:

Due to the nature of the self test procedure a fault detected on a *redundant* analog output channel may cause a dip in the output before Safety Manager switches over to the healthy channel.

Pin allocation

The back view and pin allocation of the SAO-0220m module connector are as follows:

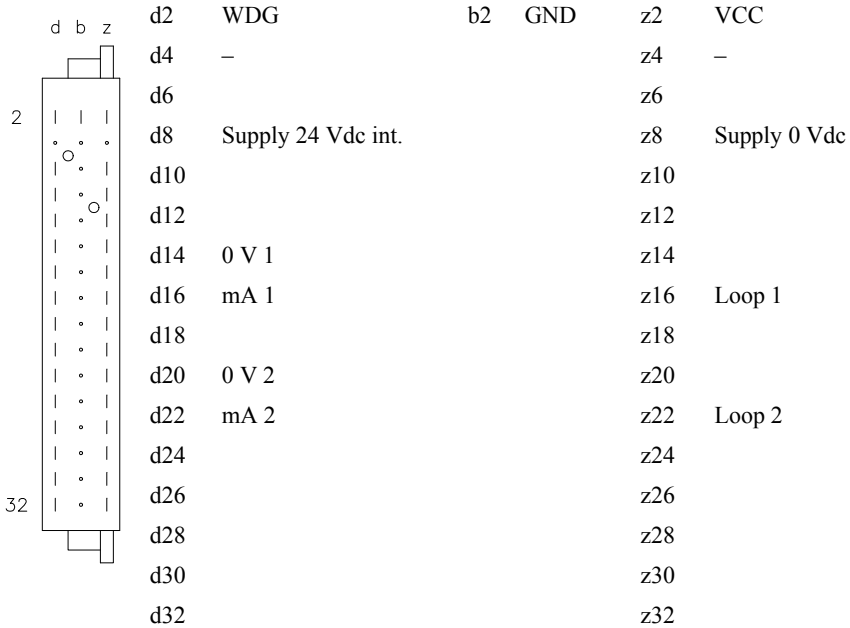

Connection examples

The figures below show a number of connection examples for the safe analog output module SAO-0220m.

Figure 212 Connection example of SAO-0220m module to FTA for non-redundant IO configurations

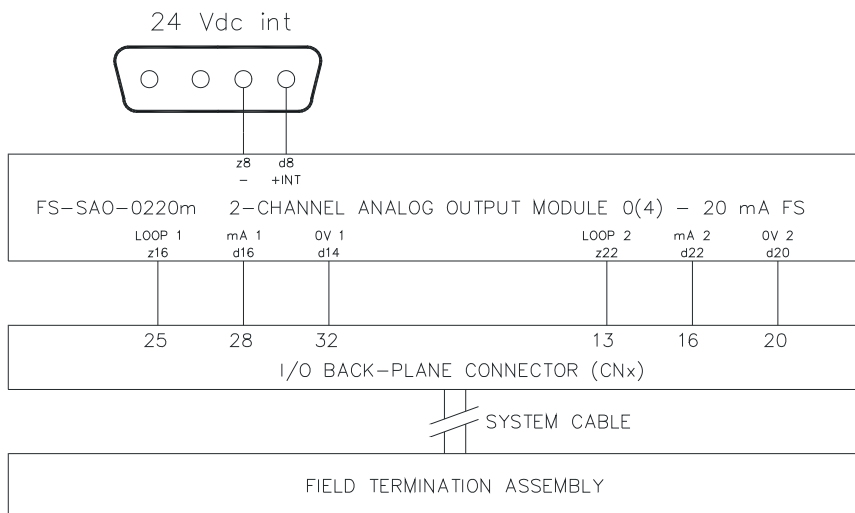

Figure 213 IO connection example for SAO-0220m module for non-redundant IO configurations (one channel active, one channel passive)

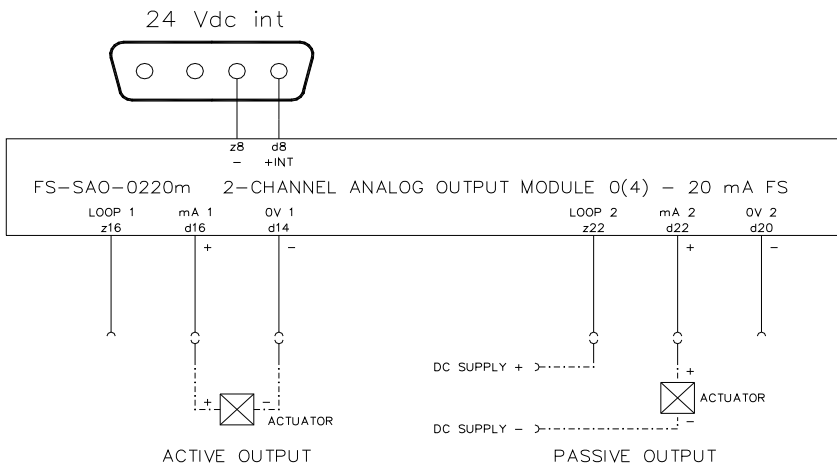
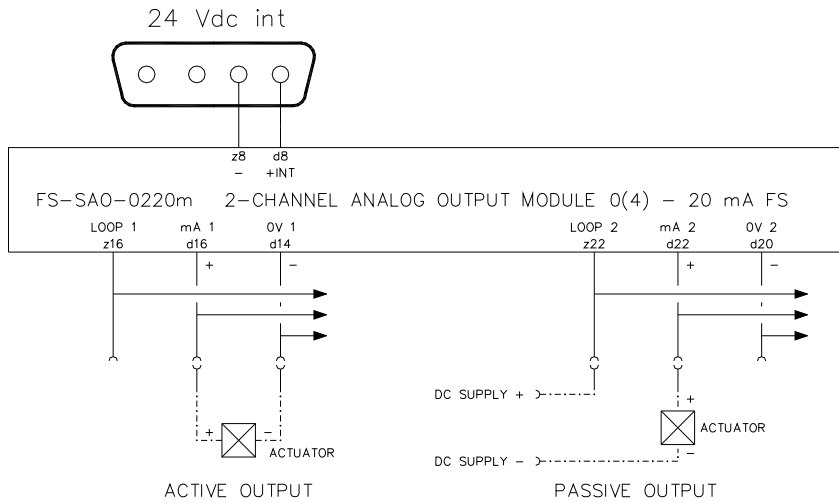

Figure 214 IO connection example for SAO-0220m module for redundant IO configurations (one channel active, one channel passive)



Note

The 24 Vdc (internal) supply must be connected to prevent fault detection during self-test. Unused outputs must be shorted to prevent fault detection during the self-test of the module. For the FTA (TSAO-0220m), you need to link terminal 2 with 3 (for channel 1) respectively terminal 6 with 7 (for channel 2)

Hazardous locations (FM 3611)

The SAO-0220m module can also be used in non-hazardous areas for non-incendiary field circuits to Division 2 locations in compliance with FM 3611 (Class I, Division 2, Groups ABCD; Class II, Division 2, Groups FG). For more details, see the FM Approval Guide EP-SM.6287.

Technical data

The SAO-0220m module has the following specifications:

General	Type numbers ¹ :	FS-SAO-0220m V1.0
		FC-SAO-0220m CCV1.0
	Approvals:	CE, TUV, UL, CSA, FM
	Space requirements:	4 TE, 3 HE (= 4 HP, 3U)
Power	Power requirements:	5 Vdc, 30 mA 24 Vdc, 65 mA +30 mA for each active output
Output	Number of output channels:	2 (Galvanically isolated from supply voltage; 0V 1 and 0V 2 interconnected)
	Output specification (mA):	Active or passive, 0—20 / 4—20 mA
	D/A converter:	12-bit
	Off current:	< 0.05 mA
	Loop powering (active):	Maximum loop resistance: 600 Ω Maximum output voltage: 30 Vdc
	External powering (passive):	Maximum: 40 Vdc Minimum voltage drop: ≤ 7.5 V
	WDG input current:	0.5 mA
Key Coding	(See section “Key coding” on page 17)	
	Module code:	
	• Holes	A9, C5
	Chassis code:	
	• Large pins	A9, C5

- ¹ FS-type modules are non conformal coated modules.
FC-type modules are conformal coated modules. Conformal coated modules have the letters “CC” preceding the version number.