

ICR880/890 Camera Systems



Camera Systems for Reading 1D/2D Codes with Superb Image
Quality suitable for OCR and Video Coding Applications



Software Versions

Software/Tool	Function	Version
ICR880/890	SICK Firmware	From V. 3.x
SOPAS-ET ^{*)}	Configuration software (Windows-based)	From V. 2.38
*) runs on a PC under Windows™ operating system		

NOTICE

RF interferences in case of use in residential areas!

- The ICR880/890 Camera Systems are exclusively intended for use in industrial areas.

Copyright

Copyright © 2006 - 2013

SICK AG Waldkirch

Division Identification & Measuring, Reute plant

Nimburger Strasse 11

79276 Reute

Germany

Trademarks

Windows 2000™, XP™, Vista™ and Windows 7™ are registered trademarks or trademarks of the Microsoft Corporation in the USA and other countries.

Adobe® Reader® is a trademark of Adobe Systems Incorporated.

Download from the website at the internet: <http://get.adobe.com/reader/>.

Latest manual version

For the latest version of this manual (PDF), see www.sick.com.

Table of Contents

1	Notes on this document	7
1.1	Purpose.....	7
1.2	Target audience	8
1.3	Information content	8
1.4	Symbols used	9
2	Safety information	11
2.1	Authorized users	11
2.2	Intended use.....	11
2.3	General safety precautions and protection measures	12
2.4	Quick stop and quick start.....	15
2.5	Environmental information.....	15
3	Product description	17
3.1	Design of the Camera System	17
3.2	System requirements.....	21
3.3	Product features and functions (overview)	23
3.4	Method of operation	24
3.5	Indicators and control elements	32
4	Installation	35
4.1	Overview of installation sequence	35
4.2	Installation preparations	35
4.3	Installing and adjusting the Camera System	38
4.4	Installing external components.....	41
4.5	Removing the device.....	42
5	Electrical installation	43
5.1	Overview of installation sequence	43
5.2	Electrical installation preparation	43
5.3	Electrical connections and cables	48
5.4	Performing electrical installation	52
5.5	Pin assignments and conductor coloring assignment.....	59
6	Startup and Configuration	65
6.1	Overview of the startup procedure	65
6.2	SOPAS-ET Configuration Software	65
6.3	Establishing communication with the Camera System/MSC800	66
6.4	First startup	68
6.5	Default setting.....	69
7	Maintenance	71
7.1	Maintenance during operation.....	71
7.2	Cleaning the Camera System	71
7.3	Replacing a Camera System or a component.....	75
7.4	Disposal	77
8	Troubleshooting	79
8.1	Overview of errors and malfunctions which could occur.....	79
8.2	Detailed malfunction analysis.....	79
8.3	SICK support.....	80
9	Technical data	81
9.1	Data sheet for ICD880/ICD890 Camera.....	81
9.2	Data sheet for ICI890 Illuminations.....	83
9.3	Data sheet for deflection mirrors.....	83
9.4	Specification diagrams	84
9.5	ICR880/890 Camera System dimensional drawing.....	86
9.6	Deflection mirrors dimensional drawing.....	88
9.7	EC Declaration of Conformity	89
10	Appendix	91
10.1	Appendix overview	91
10.2	Configuring the Camera System with command strings	91

10.3	Ordering information	92
10.4	Supplementary documentation	92
10.5	Glossary	93
10.6	Tables and Figures	96

Abbreviations

BMP	Bitmap (pixel-oriented Windows format for saving photos)
CAN	Controller Area Network (field bus protocol based on the CAN bus)
CMOS	Complementary metal-oxide-semiconductor
DOF	Depth Of Field
dpi	dots per inch (1 inch = 25.4 mm)
EEPROM	Electrically Erasable Programmable Read Only Memory
FIFO	First In First Out
FTP	File Transfer Protocol
HTML	Hyper Text Markup Language
I	Input
ICD	Image Capture Device
ICI	Image Capture Illumination
ICR	Image Code Reader (High-end CMOS Camera System)
JPEG	Joint Photographic Expert Group (pixel-oriented file format for saving high compression photos, compression process for tiff formats)
LED	Light Emitting Diode
LIFO	Last In First Out
lpi	Lines per inch (1 inch = 25.4 mm)
MAC	Medium Access Control
MLG	Modular Light Grid
MSC	Modular System Controller (MSC800)
MTBF	Mean Time Between Failure
MTTR	Mean Time To Repair
O	Output
OCR	Optical Character Recognition
PLC	Programmable Logic Controllers
RAM	Random Access Memory
RoHS	Restriction of (the use of certain) Hazardous Substances
ROM	Read Only Memory
SD	Secure Digital Card
SMART	SICK Modular Advanced Recognition Technology
SOPAS-ET	SICK Open Portal for Application and Systems Engineering Tool (PC software for Windows for configuration of the ICR86x System and the MSC800)
TCP/IP	Transmission Control Protocol/Internet Protocol
UDP	User Datagram Protocol
VCS	Video Coding System
VMS	Volume Measuring System

For a list of tables and figures see [Chapter 10.6, Page 96](#).

Notes:

1 Notes on this document

1.1 Purpose

This document provides instructions for **technical staff** on the installation and operation of the Camera Systems in the ICR880/890 series with focus control and the following variants of system components:

- **System 1:**
ICD880 Camera with standard lens (focal distance 80 mm (3.15 in)) and ICI890-x11xx illumination (length 750 mm (29.5 in))
- **System 2:**
ICD890 Camera with standard lens (focal distance 135 mm (5.32 in)) and ICI890-x10xx illumination (length 900 mm (35.4 in))
- **System 3:**
ICD890 Camera with standard lens (focal distance 135 mm (5.32 in)) and ICI890-x00xx illumination (length 1,100 mm (43.3 in))

All systems comprise a version of the co-ordinating MSC800 Controller.

A summary of all available Camera System versions is shown in [Chapter 3.1.3 Device versions, Page 20](#).

This document contains the following information about the Camera Systems:

- Safety Information
- Installation and electrical installation
- Startup and configuration
- Maintenance
- Product features and functions
- Troubleshooting
- Replacing system components
- Technical data

A step-by-step approach is taken for all tasks.

Important In this document the system components are referred to simplified terms, except where a distinction of the variants is necessary:

- ICR880 or ICR890 Camera System, simplified: Camera System
- ICD800 or ICD890 Image Capture Device, simplified: Camera
- ICI890 Image Capture Illumination, simplified: ICI890 Illumination
- MSC800 Modular System Controller, simplified: MSC800
- MLG Light Grid (Modular Light Grid), simplified: MLG Light Grid
- VMS4xx/5xx Volume Measuring System, simplified: VMS4xx/5xx
- SICK Open Portal for Application and Systems Engineering Tool, simplified: SOPAS-ET Configuration Software
- The register tabs for configuration of the Camera Systems and the MSC800 are referred to in the SOPAS-ET Configuration Software online help as "device pages".
- 1D codes generally mean bar codes also called linear codes.
2D codes generally mean stacked codes and matrix codes. [Chapter 9 Technical data, Page 81](#) lists the code types readable by the Camera System.

1.2 Target audience

The target audience of this document is persons assigned the following tasks:

Tasks	Target audience
Installation, electrical installation, maintenance, replacing system components	Qualified staff, e.g. service technicians and factory electricians
Startup and configuration	Qualified staff, e.g. technicians and engineers
Operation of the conveyor system	Qualified staff for startup and operation of the conveyor system

Tab. 1-1: Target audience of the document

1.3 Information content

This document contains all the required information for installation, electrical installation and operation of the ICR880/890 Camera Systems at the installation location. The **factory configuration** (default setting) of the Camera Systems as a **stand-alone device** is optimized to a **single-side reading** (from above or from the side).

Configuration of the Camera Systems for the **application-specific reading conditions** and operation is carried out via the SOPAS-ET Configuration Software at a Windows™-PC. The SOPAS-ET Configuration Software contains an online help system to facilitate configuration.

Installation and electrical installation of the MSC800 controller and its configuration is detailed in the *MSC800 Operating Instructions* (part no. 8011540). These instructions also described use of the MSC800 as a controller for a **multi-side reading**.

Important This document only describes customer-specific devices (hardware or functional modified) in the parts which meets the standard devices.

Further information on Camera Systems, Volume Measurement Systems and 1D/2D Code Scanners is available from SICK AG, Division Identification & Measuring.

On the Internet at www.sick.com.

1.4 Symbols used

Some of the information in this document is marked specially so that you can access it quickly:

NOTICE

Notice!

Indicates a potential risk of damage or impair on the functionality of the Camera System.



WARNING

Warning notice!

A warning notice indicates real or potential danger. This should protect you against accidents.

The safety symbol next to the warning notice indicates why there is a risk of accident. e.g. due to electricity. The warning levels (CAUTION, WARNING, DANGER) indicate the seriousness of the risk.

- Carefully read and follow the warning notices.

Reference Italics are used to refer to more detailed information elsewhere.

Important his important note informs you about specific features.

Explanation Explanations provide background information on technical correlations.

Recommendation Recommendations help you carry out certain procedures more effectively.

TIP Tips explain settings in the SOPAS-ET Configuration Software.

PROJECT This font indicates a term in the user interface of the SOPAS-ET Configuration Software.



Icons refer to buttons in the user interface of the SOPAS-ET Configuration Software.

"0x0" This font indicates messages output by the Camera System.

This symbol identifies sections that describe steps carried out with the SOPAS-ET Configuration Software.



This symbol refers to additional technical documentation.

- There is a procedure which needs to be carried out. This symbol indicates operational instructions which only contain one operational step or operational steps in warning notices which do not have to be followed in any particular order.

Operational instructions comprising several steps in definite order are denoted using consecutive numbers.

- ⇒ This symbol indicates a glossary entry.

Notes:

2 Safety information

This chapter deals with your safety and operator safety of the conveyor system.

- Read this chapter carefully **before** using the Camera Systems.

2.1 Authorized users

For correct and safe functioning, the Camera System must be installed, operated and maintained by sufficiently qualified staff.

NOTICE

Risk of damage!

Repairs to the ICR880/890 Camera Systems should only be carried out by qualified and authorized SICK AG service staff.

- The operating instructions should be made available to the end user.
- The end user should be briefed and urged to read the operating instructions by the technicians.

The following chapters summarize the required qualifications for the various tasks.

Tasks	Qualification
Installation, maintenance	<ul style="list-style-type: none"> - Practical technical training - Knowledge of current health and safety regulations at the work-place
Electrical installation, replacing the device	<ul style="list-style-type: none"> - Practical electrical training - Knowledge of current electrical safety regulations - Knowledge of startup and operation of the device in each operational area (e.g. conveyor system)
Startup and configuration	<ul style="list-style-type: none"> - Basic knowledge of the Windows™ operating system - Basic knowledge of designing and setting up (addressing) Ethernet connections for connecting the Camera System to the Ethernet - Basic knowledge of data transfer - Basic knowledge of 1D/2D code technology
Operation of the device in each operational area	<ul style="list-style-type: none"> - Knowledge of the mechanical and electrical parameters of the conveyor system and the characteristics of the conveyor system regarding startup and operation - Knowledge of the software and hardware environment in each operational area (e.g. conveyor system)

Tab. 2-1: Required qualification for starting up the Camera System

2.2 Intended use

The ICR880/890 Camera System is an intelligent sensor for the recognition and decoding of 1D/2D codes on moving objects in a reading station. In combination with the co-ordinating MSC800 modular system controller and further system components the Camera System presents an automatic reading system.

With the MSC800 modular system controller, the Camera System is used as a stand-alone device for single-side reading, e.g. from above or from the side. For a similarly possible multi-side reading on the conveyor system, the corresponding number of Camera Systems is combined with other SICK bar code scanners and with the MSC800.

The intended use of the Camera System results from the following description of the system components and their functions:

- Depending on type, the Camera System consists of the ICD880 or ICD890 Camera as well as of an aligned combination of an ICI890 Illumination variant and an optional deflection mirror variant. The Camera is installed in a frame together with the ICI890 Illumination as a unit parallel to the optional deflection mirror, either above the conveyor system (reading from above) or at the side (side reading).
- The necessary object distance information is contained in the Camera System either by an MLG Light Grid (in the case of readings from above) or by a VMS4xx/5xx Volume Measurement System for focus control during single or multi-side reading.
- The Camera System transfers the reading data, with optionally selectable diagnosis data, via the CAN interface to the MSC800. The MSC800 outputs the data via its HOST data interface (serial RS 232, RS 422/485, Ethernet or CAN) to a superordinate host processor for further processing.
- The processed image information of the Camera is located on two fast GBit Ethernet channels. The image information can be transferred to the client display at extremely high data transfer rates on a special PC with compatible GBit Ethernet interface cards. The high image quality also allows use in OCR and video coding applications.
- Configuration/Operation of the Camera System is carried out as standard via the AUX auxiliary data interface (Ethernet port or serial RS 232) of the MSC800 using the SO-PAS-ET Configuration Software, which runs on a standard client PC.

Important Any warranty claims against SICK AG shall be deemed invalid in the case of other Camera System use or Camera System modifications, this includes modifications during installation and electrical installation or changes to the SICK software. However, the camera or the illumination can be rapidly replaced by the user.

- Only operate the Camera System in ambient air temperature limit in indoor areas (see [Chapter 9 Technical data, Page 81](#)).

2.3 General safety precautions and protection measures

- Read the general safety precautions thoroughly and observe them during all ICR880/890 Camera System activities. Also observe the warning notices above the operational instructions of each chapter.

2.3.1 Radio interferences

NOTICE

RF interferences in case of use in residential areas!

- The ICR880/890 Camera Systems are exclusively intended for use in industrial areas.

2.3.2 Installation work



CAUTION

Risk of injuries due to falling components!

Depending on type, the combined weight of the Camera and the ICI890 Illumination is max. 37 kg (81.6 lb.) without installation accessories.

- Do **not** carry out installation work alone.
- A second person should always secure components during installation.

2.3.3 Electrical installation work



DANGER

Risk of injury by electrical current!

The MSC800 Controller is connected to a mains voltage of 100 V to 264 V AC/50 Hz to 60 Hz.

- Observe current safety regulations when working with electrical equipment.

- Important**
- Electrical installation should only be carried out by qualified staff.
 - Connect or disconnect current linkages only under de-energized conditions.
 - Wire cross sections and their correct protection have to be selected and implemented according to valid engineering standards. The fuse must be at the beginning of the cable after the power supply unit.

Connecting a dongle to camera variants with USB connection

Some special camera devices provide an additional USB connection located on the side. In reading mode, the connection must always be covered by the metal cap ([Fig. 2-1](#)).

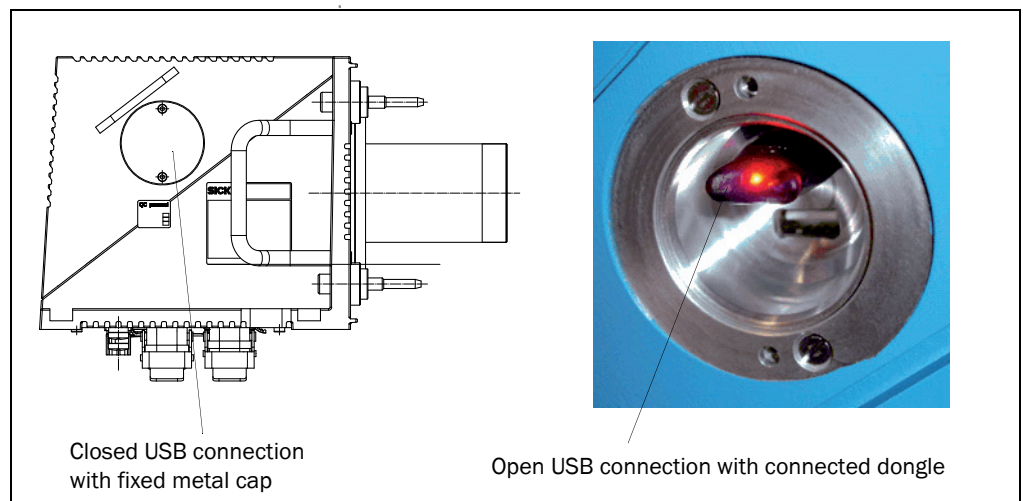

Fig. 2-1: Location of the optional USB connection on the side of the camera

The connection with 2 USB ports (type A sockets) is used for connecting dongles.

- Important** Other USB capable devices may not be connected.

NOTICE

Risk of damage!

If the USB connection is not handled in correct manner, the electronics of the camera can be damaged.

- Connect or disconnect a dongle to/from the sockets only when the **Camera System is de-energized**.
- Before connecting or disconnecting a dongle, equipotential bonding must be provided between the body of the operator and the camera.
During work, wear grounding wrist straps to avoid ESD damage.
- In reading mode, only operate the camera with fixed cap of the USB connection due to the EMC concept.

2.3.4 LED radiation from the ICI890 Illumination



CAUTION

LED radiation!

The Camera Systems ICR880 and ICR890 are classified in LED risk group RG 1 according to IEC 62471-1:2006-07/EN 62471-1:2008-09. The illumination type-dependent uses LEDs with red, blue or white light.

The entire window surface is the LED radiation outlet opening.

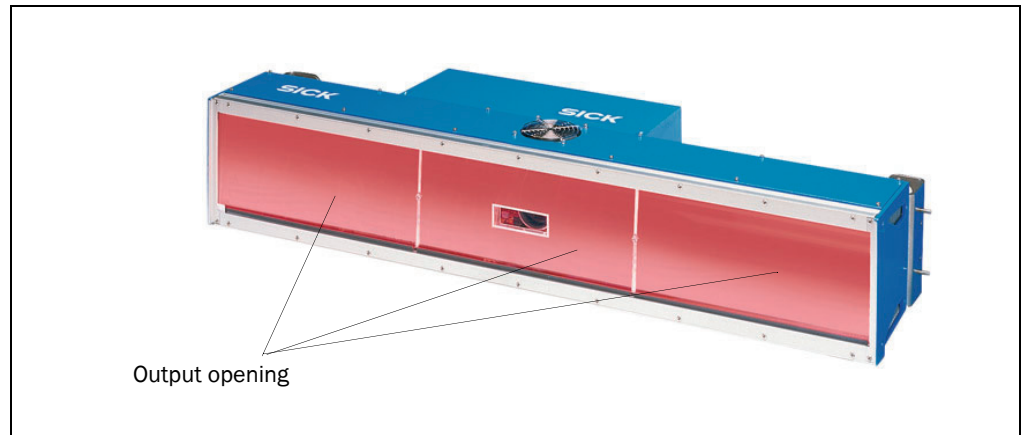

Fig. 2-2: LED radiation outlet opening of the ICI890 Illumination

The accessible radiation from the LEDs does not represent a risk due to the normal restrictions imposed by human behavior. It is not possible to entirely rule out temporary, disorientating optical effects on the human eye (e.g. dazzle, flash blindness, afterimages, impairment of color vision), in particular in conditions of dim lighting. No safety measures are required.

Caution – use of controls, adjustments or performance of procedures other than those specified herein may result in hazardous radiation exposure.

- Do not deliberately look directly into the illumination for a lengthy period.
- Do not open the housing. (The illumination is **not** switched off if the housing is opened).
- Always observe the latest valid version of optical radiation protection regulations for photobiological safety of lamps and lamp systems.

Radiation power

The ICI890 Illumination type-dependent uses LEDs with the following wavelengths:

- Red light: $\lambda = 620 \text{ nm}$ (amber)
- Blue and white light: $\lambda = 470 \text{ nm}$

The radiation emitted is not harmful to human skin.

Important Maintenance is not required to ensure compliance with LED risk group RG 1.

The ICI890 Illumination operates as follows:

- The reading pulse (pulse source) controls the on and off mechanism of the LED illumination during the reading process. **The LEDs are switched on in pulsed mode during the reading operation depending on the reading gate duration.**
- A time stage (illumination timeout) automatically switches off the illumination during the reading operation after 3 seconds (default setting) following the start of a continu-

ous reading pulse. This, however, does not switch off the reading pulse. The reading pulse should be stopped via a relevant pulse signal. The next reading pulse switches the illumination back on.

- The illumination timeout can be set or switched off within a range of 3 s to 25 h. For safety reasons, the minimum illumination power on time is 3 seconds.

2.4 Quick stop and quick start

The Camera System is operated via the MSC800 Controller as standard and can be switched on and off using the controller main switch.

2.4.1 Switch off the Camera System

- Switch off the power supply of the MSC800.

When the Camera System is switched off the following data is lost:

- Application-specific parameter sets in the Camera System and in the MSC800 Controller which were only **temporarily** saved in the devices
- The last reading result of the Camera System
- Daily operating hours counter of the Camera System

2.4.2 Switch on the Camera System

- Switch on the power supply of the MSC800 again.
The Camera System starts up using the most recent **permanently** saved configuration. The daily operating hours counter is reset.

2.5 Environmental information

The Camera System has been constructed with minimum environmental pollution in mind. Excluding the housing, the Camera System does not contain any materials using silicone.

2.5.1 Energy requirements

The Camera System is electrically powered via the MSC800 Controller as standard (functional extra-low voltage in accordance with IEC 60364-4-41). The Camera System and the logic controller of the MSC800 controller have the following power consumption at 24 V DC ± 20 % and ambient temperature 20 °C (68 °F):

Device type	Power consumption
ICR880/890 Camera	typical 75 W (via power supply unit of MSC800)
ICI890 illumination (via power supply unit of MSC800)	Red Illumination (amber): ICI890-00000 (1,100 mm(43.34in)): typical 160 W ICI890-01000 (900 mm(35.46 in)): typical 130 W ICI890-01100 (900 mm(35.46 in)): typical 130 W ICI890-02100 (750 mm (29.55 in)): typical 80 W Blue/white Illumination: ICI890-10000 (1,100 mm(43.34in)): typical 260 W ICI890-11000 (900 mm(35.46 in)): typical 210 W ICI890-11100 (900 mm(35.46 in)): typical 210 W ICI890-12100 (750 mm (29.55 in)): typical 130 W
MSC800-0000 (logic controller)	typical 10 W

Tab. 2-2: Power consumption of the Camera System

2.5.2 Dispose of the device after decommissioning

At present SICK AG will not accept the return of any devices which can no longer be operated or repaired.

- Inoperable or irreparable devices must be disposed of in an environmentally friendly manner and in accordance with valid country-specific waste disposal guidelines.

The design of the Camera System allows for its separation as recyclable secondary raw materials and hazardous waste (electronic scrap).

Important The battery on the internal PC card of the Camera must be removed before the device is scrapped.

- Dispose of the battery separately in accordance with RoHS regulations (Europe).

3 Product description

This chapter describes the design, the features and the functions of the Camera System.

- For installation, electrical installation and startup assistance as well as system configuration using the SOPAS-ET Configuration Software, please read this chapter **prior** to carrying out any of the tasks.

3.1 Design of the Camera System

The Camera System consists of the **ICD880** or **ICD890** Camera (Image Capture Device), the **ICI890** Illumination (Image Capture Illumination) and an optional deflection mirror. The Camera System is operated in combination with the **MSC800** (Modular System Controller) via a CAN bus. The MSC800 supplies the Camera System with power.



For further information on the MSC800, see the *MSC800 Operating Instructions* (part no. 8011540).

External sensors are required for the reading pulse, detection of the object distance and for creation of the increment signal. These sensors and the superordinate host processor are connected to the MSC800.

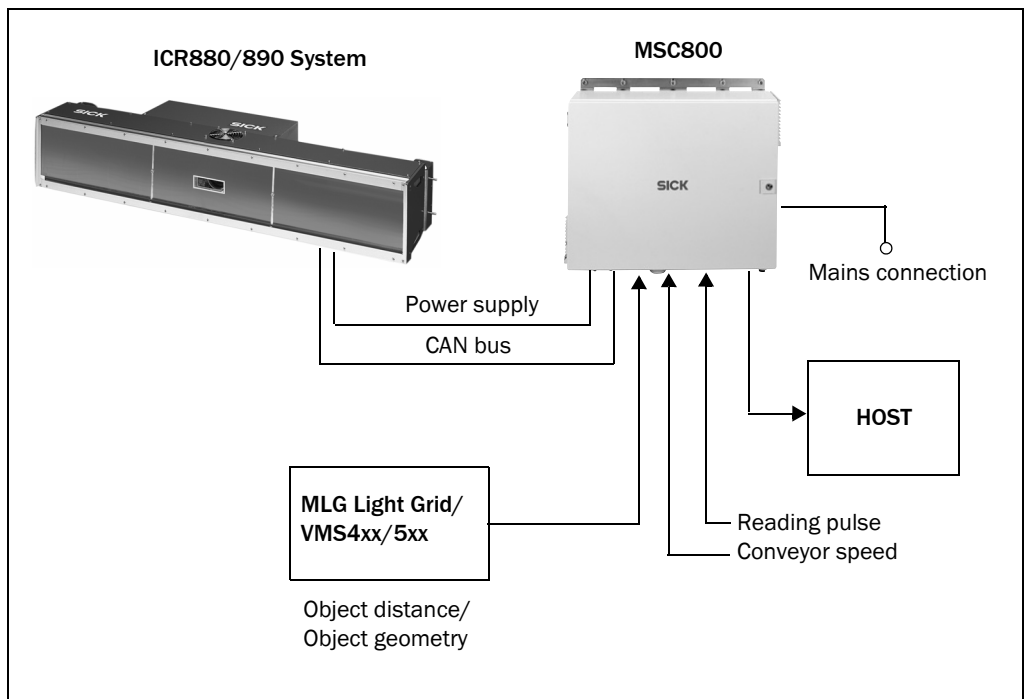

Fig. 3-1: ICR880/890 Camera System in combination with the MSC800 (single-side reading)

3.1.1 Device view

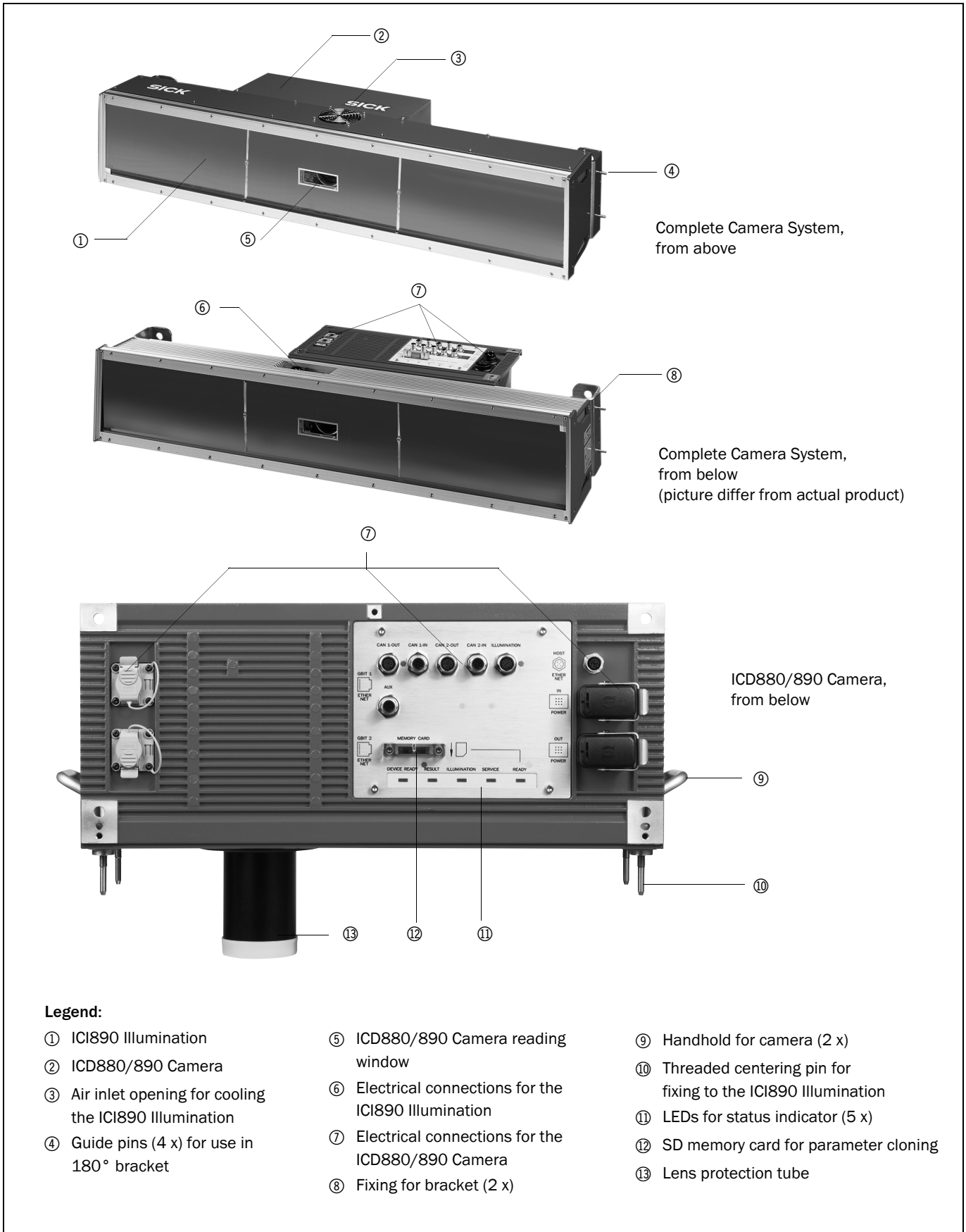

Fig. 3-2: View of the ICD880/890 Camera and the ICI890 Illumination

3.1.2 Included in delivery

Delivery of the ICR880/890 Camera System includes the following components:

Piece(s)	Components	Comment
1	Camera with SD memory card	ICD880 or ICD890, depending on order
1	ICI890 Illumination	Type-dependending
1	Deflection mirror (optional)	Type-dependending
1	MSC800	Type-dependending, without connection cables
1	MLG Light Grid (pre-configured) height distance detector with connection cable and installation kit	Application-specific
1	- or - Object distance detector VMS4xx/5xx with connection cables and installation kit	
4	180° brackets with installation accessories	For Camera System and deflection mirror
1	WL18-3 Reading Pulse Sensor (pulse photoelectric reflex switch) with connection cable and installation kit	Triggering the reading procedure
1	Connection cable	For the power supply of the Camera System
1	Connection cable	For the power supply of the ICI890 Illumination via the camera
1	Connection cable	For control of the ICI890 Illumination via the camera
1	CAN bus data link	For networking the Camera System with MSC800 via the CAN bus
1	Terminal resistance	For CAN bus termination at the Camera System
1	Incremental encoder, resolution 10 mm (394 mil)/pulse	Optional (application-specific)
1	- or - Incremental encoder, resolution 0.2 mm (7.9 mil)/pulse (using VMS4xx/5xx)	
	Installation frames	Optional (application-specific)
1	Notes on Device with electrical connection diagram as primary information	Included in the device packaging of the Camera System

Tab. 3-1: Included in the delivery of the ICR880/890 Camera System

Important For save operation of the SD memory card, use only SICK approved memory card. An overview of cleaning agents for the front window of the illumination is available in [Chapter 10.3, Page 92](#).

3.1.3 Device versions

The camera and the ICI890 Illumination are available in the following versions:

Type	Part no.	Description
Camera with lens		
ICD880-3112100	1061170	Max. 19 kHz, lens: focal distance 80 mm (3.15 in), reading distance 0.75 m to 1.4 m (2.46 ft o 4.59 ft)
ICD890-3200100	1061166	Max. 19 kHz, lens: focal distance 135 mm (5.32 in), reading distance 1.4 m to 3.0 m (4.59 ft to 9.84 ft)
ICD890-3201100	1061167	Max. 19 kHz, lens: focal distance 135 mm (5.32 in), reading distance 1.6 m to 3.3 m (5.24ft to 10.82 ft)
ICD890-3300100	1061168	Max. 30 kHz, lens: focal distance 135 mm (5.32 in), reading distance 1.4 m to 3.0 m (4.59 ft to 9.84 ft)
ICD890-3301100	1061169	Max. 30 kHz, lens: focal distance 135 mm (5.32 in), reading distance 1.6 m to 3.3 m (5.24 ft to 10.82 ft)
LED Illumination		
ICI890-00000	1028219	Red, profile length 1,100 mm (43.3 in), for focal distance 135 mm (5.32 in)
ICI890-01000	1046888	Red, profile length 900 mm (35.4 in), for focal distance 135 mm (5.32 in)
ICI890-01100	1051413	Red, profile length 900 mm (35.4 in), for focal distance 80 mm (3.15 in)
ICI890-02100	1048455	Red, profile length 750 mm (29.5 in), for focal distance 80 mm (3.15 in)
ICI890-10000	1054855	Blue and white, profile length 1,100 mm (43.3 in), for focal distance 135 mm (5.32 in)
ICI890-11000	1054856	Blue and white, profile length 900 mm (35.4 in), for focal distance 135 mm (5.32 in)
ICI890-11100	1054857	Blue and white, profile length 900 mm (35.4 in), for focal distance 80 mm (3.15 in)
ICI890-12100	1054858	Blue and white, profile length 750 mm (29.5 in), for focal distance 80 mm (3.15 in)

Tab. 3-2: System component versions

In combination of the components result in the following Camera Systems:

Property	System 1	System 2	System 3
System width	770 mm (30.34 in)	950 mm (37.43 in)	1,150 mm (45.31 in)
Max. reading distance	1,400 mm (55.2 in)	2,500 mm (98.5 in)	3,300 mm (130 in)
Depth of field	550 mm (21.6 in)	1,100 mm (43.3 in)	1,700 mm (66.98 in)
Typical track width cover	≤ 600 mm (23.6 in)	≤ 800 mm (31.5 in)	≤ 1,300 mm (51.22 in)
Typical image resolution	200 dpi to 270 dpi	200 dpi to 250 dpi	150 dpi to 200 dpi
Image lift	Tracking, analysis, VCS	Tracking, analysis, OCR, VCS	Tracking, analysis, OCR, VCS

Tab. 3-3: Camera Systems versions

3.2 System requirements

3.2.1 Installation requirements

- Typical space requirements above the highest object (for reading from above): application-specific
- Unobstructed view of the objects for the Camera System
- Stable installation frames with sufficient load capacity and measurements suited to the Camera System (see [Chapter 9.5 ICR880/890 Camera System dimensional drawing, Page 86](#))
- Four 180° brackets for the Camera System/the deflection mirror (included in delivery)
- Shock absorbent and vibration free attachment

Important An installation frame made of 80 mm (3.15 in) item aluminium profiles can be used for simple system installation ([Fig. 3-3](#)). The 180° brackets are aligned to these profiles.

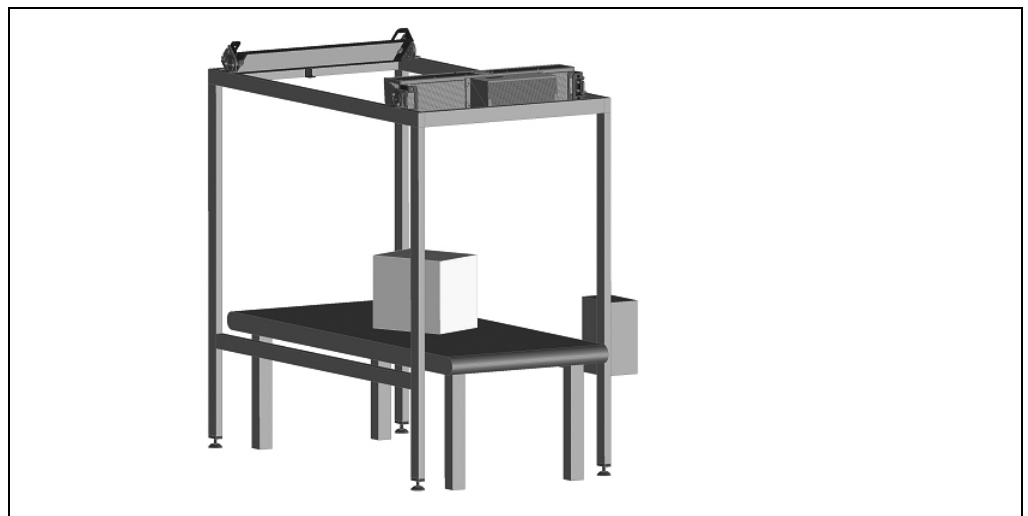

Fig. 3-3: Example of simple Camera System installation on the installation frame

3.2.2 Electrical installation requirements

- Power supply (via MSC800): 100 V to 264 V AC/50 Hz to 60 Hz
- Reading pulse sensor (start/stop), e.g. photoelectric reflex switch (included in delivery): For detecting an object with external reading pulse
- Additional appropriate reading pulse sensor (stop), e.g. photoelectric reflex switch: For detecting the end of pulse with extended external reading pulse
- Pre-configured MLG Light Grid (included in delivery): when reading from above to detect the object distance
- VMS4xx/5xx Volume Measurement System: when reading from the side or for multi-side reading to detect the object distance
- Suitable incremental encoder, e.g. part no. 2058477 (resolution 10 mm (394 mil)/pulse). Device is included in delivery depending on the system configuration
- Host computer with RS 232, RS 422/485, Ethernet or PROFIBUS-DP data interface: For further processing of the reading data via MSC800
- Suitable visualization PC or PLC: To display the system status
- Connection cables: See [Chapter 5.3.4, Page 51](#)

3.2.3 Starting up and configuration requirements

- PC in the following version:
 - Minimum Pentium III, 500 MHz, 512 MB RAM, CD drive, RS 232 serial data interface or Ethernet interface card, mouse (recommended) and color monitor (recommended resolution 1,024 x 768 pixels)
 - Operating system Windows 2000™, XP™, Vista™ or Windows 7™
 - Free storage space on the hard drive: Approx. 300 MB for the SOPAS-ET Configuration Software (V. 2.38) with help files
- Connection cables see: [Chapter 5.3.4, Page 51](#)

ICR880/890

3.3 Product features and functions (overview)

Feature	Characteristics
ICD880/890 Camera	<ul style="list-style-type: none"> • CMOS line with 8,192 pixels (standard device) • Dynamic focus setting • ICD880: lens with focal point distance 80 mm (3.15 in), ICD890: lens with focal point distance 135 mm (5.32 in) • Type-dependent reading ranges (z.B. standard device ICD890: 1.4 m to 3.0 m (4.59 to 9.84 ft)) • Type-dependent image resolution (e.g. standard device ICD890: 170 to 350 dpi) • Scanning frequency max. 19.1 kHz (standard device)/max. 30 kHz (high speed device) • Can be adapted to the print quality of the code • Analysis area of the CMOS line can be restricted • Real time image output (grey values: "*.jpg", "*.tif")
User safety and convenience	<ul style="list-style-type: none"> • Robust, compact metal housing, enclosure rating max. IP 64, CE mark • Laser class 1M, switching off the LED ICI890 illumination in case of prolonged active reading gate or if the output capacity is exceeded, minimum power on-time 3 s • Automatic self-test on system startup • Diagnosis tools for system setup and system (distance) monitoring • Configurable reading diagnosis data display in two reading result formats • Operational data retrieval, error code display on request in case of errors • Activatable test string function for signalling readiness for operation • Password protected configuration mode • Back up of configuration parameter values (cloning) also on SD memory card (can be removed when replacing the camera) • Future proof due to firmware update (flash PROM) via data interface • Future proof SOPAS-ET Configuration Software • Extended power supply voltage range • Necessary maintenance or service task displayed via LED and system report • The camera or illumination can be replaced within 10 min
Convenient configuration	<ul style="list-style-type: none"> • Configuration (online/offline) and display of image memory contents via the SOPAS-ET Configuration Software (incl. help system) • Status indicators via five LEDs
Operating modes	<ul style="list-style-type: none"> • Configuration mode • Reading operation
Reading operation mode	<ul style="list-style-type: none"> • Object tracking (max. 10 objects per second, minimum gap 50 mm (1.97 in))
Reading pulse	<ul style="list-style-type: none"> • External reading pulse via MSC800
1D/2D code detection	<ul style="list-style-type: none"> • Data Matrix ECC200, PDF417, Maxicode, QR code / all conventional bar codes • Max. number of 1D codes: 50 per reading pulse • Max. number of 2D codes: 10 per reading pulse • Separation of identical codes of the same code type using the code position • Output sorting: Code position, FIFO, LIFO, code lengths list • Manipulation of output strings via filter or format masks
Data communication	<ul style="list-style-type: none"> • Main data interface HOST (via MSC800): • AUX auxiliary data interface: Fixed output format with special diagnosis functions, communication via RS 232 or Ethernet interface, application for configuration/diagnosis • Two 1 GBit Ethernet interfaces for fast image output
Electrical interface	<ul style="list-style-type: none"> • AUX data interface: RS 232 serial, Ethernet or CAN (fixed transfer rate, data format and protocol) • CAN interface for integration into SICK CAN-SENSOR Network with the MSC800 • Ethernet interface (10/100 MBps), TCP/IP and FTP • Two 1 GBit Ethernet interfaces, FTP • Connection to PROFIBUS-DP via MSC800
Connection technology (design)	<ul style="list-style-type: none"> • Data and function interfaces: M12 connector for industrial use • GBit Ethernet: Phoenix VARIOSUB RJ-45 sockets, enclosure rating IP 67 • Power supply: Harting plug-in connectors

Tab. 3-4: Product features and functions of the ICR880/890 Camera System (overview)

3.4 Method of operation

This Camera System is an intelligent sensor system for automatic and non-contact detection and decoding of 1D/2D codes. In principle, the codes can be detected on any side of moving objects in a conveyor system.

For **single-side readings**, the codes are detected from above, below or from the side using a **Camera**. In order to allow easier installation and setup of the Camera System, the Camera image is recorded using a deflection mirror.

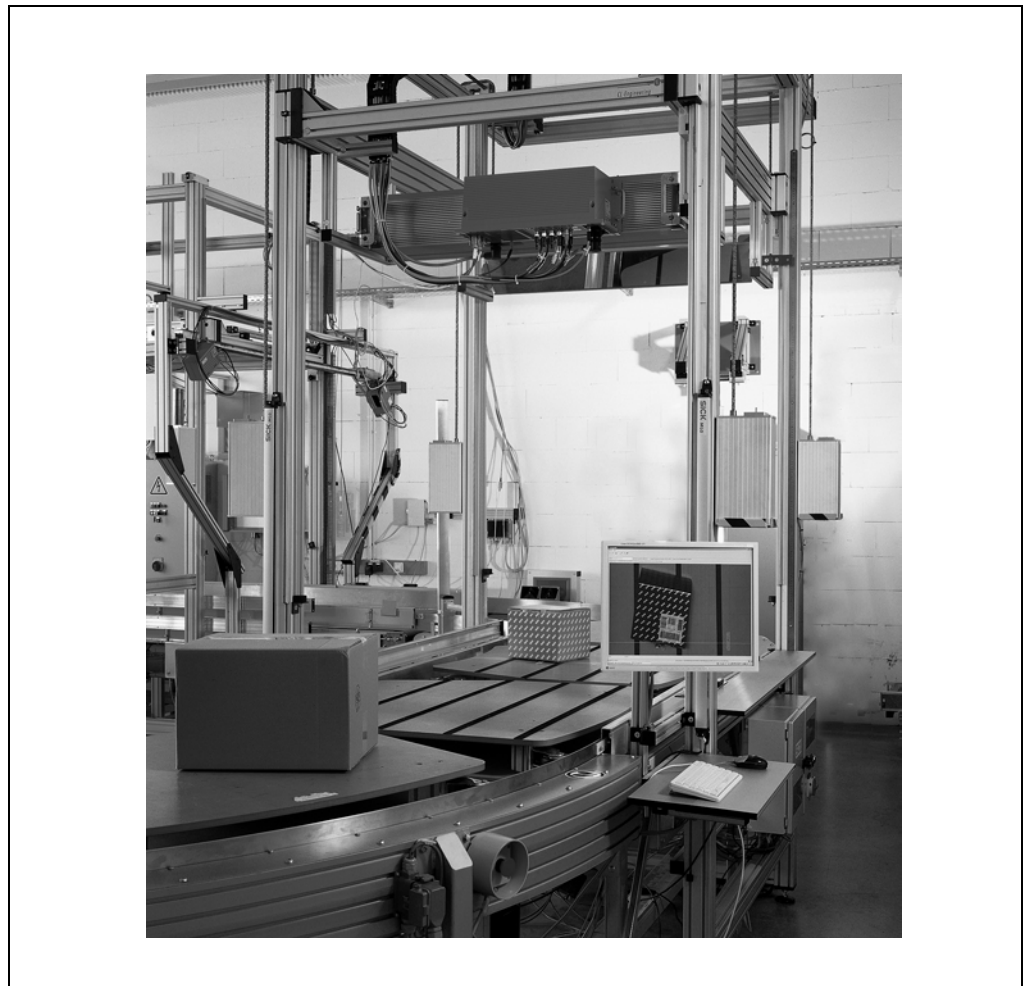

Fig. 3-4: Example: The ICR880/890 Camera System at a conveyor system, single-side reading from above

Important Several Cameras can be combined to allow detection of several sides in one passage (**multi-side reading**). The method of operation is described here using the example of single-side reading from above.

The Camera System is operated in combination with an MSC800 Controller ([Fig. 3-5, Page 25](#)). The reading results are output at the data interfaces via the controller. External sensors deliver information via the reading pulse, the object distance and the conveyor speed.

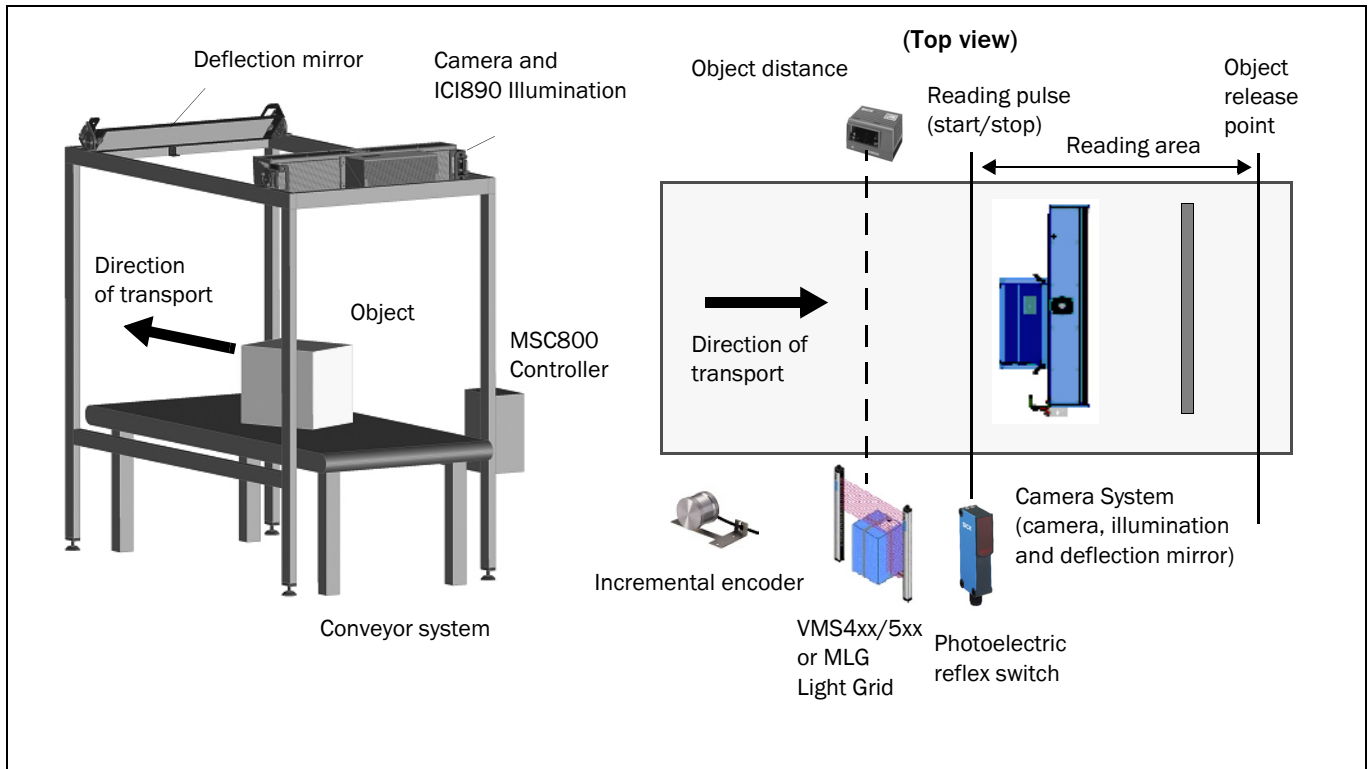

Fig. 3-5: Reading system diagram for single-side reading from above

3.4.1 Reading configuration

The **Camera** detects 1D/2D codes line by line with the help of a CMOS line. The lines are written successively and with a high frequency into an image storage. Continuous feeding of the object on the conveyor system produces a two-dimensional image of the object.

Important The Camera System cannot recognize codes on stationary objects.

A moving 1D/2D code on an object is displayed as a grey level matrix in the image storage. Contrast jumps are analyzed in order to scan the codes. The threshold value can be adapted to the ambient conditions.

For more rapid analysis, the analysis area can be restricted to across the direction of transport (code position).



The SOPAS-ET Configuration Software can, among other things, be used to configure features, such as the code position and the symbol contrast:

PROJECT TREE, ICR880/890, PARAMETER, READING CONFIGURATION, register tab CODELABEL PROPERTIES

Moreover, the image resolution across the direction of transport (digital zoom in dpi) and in the direction of transport (dynamic scanning frequency in lpi) can be configured:

PROJECT TREE, ICR880/890, PARAMETER, READING CONFIGURATION, register tab DECODER

3.4.2 Object trigger control

In order to initiate a reading process, the Camera System requires an appropriate signal (trigger). The start signal is emitted via an external reading pulse sensor (**photoelectric reflex switch**) as standard. As soon as an object has passed the reading pulse sensor, an "internal reading gate" opens for the reading process.

Alternatively, a command activates the reading process via a data interface or the CAN-SENSOR network.



The trigger source can be configured using the SOPAS-ET Configuration Software:

PROJECT TREE, ICR880/890, PARAMETER, READING CONFIGURATION, OBJECT TRIGGER CONTROL, register tab START/STOP OF OBJECT TRIGGER

3.4.3 Focus control

For dynamic focus control, the Camera requires continuous information on the distance to the object surface. This data is provided by a lateral **MLG Light Grid** for readings from above. The object dimensions are taken from the **VMS4xx/5xx Volume Measurement System** and processed via the MSC800 for readings from the side.



The SOPAS-ET Configuration Software can, among other things, be used to configure features, such as the default position and the source of the distance measurement:

PROJECT TREE, ICR880/890, PARAMETER, READING CONFIGURATION, FOCUS CONTROL, register tabs OPTIONS and DISTANCE MEASUREMENT SOURCE

3.4.4 Illumination control

The area which is to be read must be illuminated with a high-performance LED illumination when recording with the Camera. The **ICI890 Illumination** produces type-dependent a thin red illuminated area ($\lambda = 620 \text{ nm}$) or a bluish white illuminated area ($\lambda = 470 \text{ nm}$).

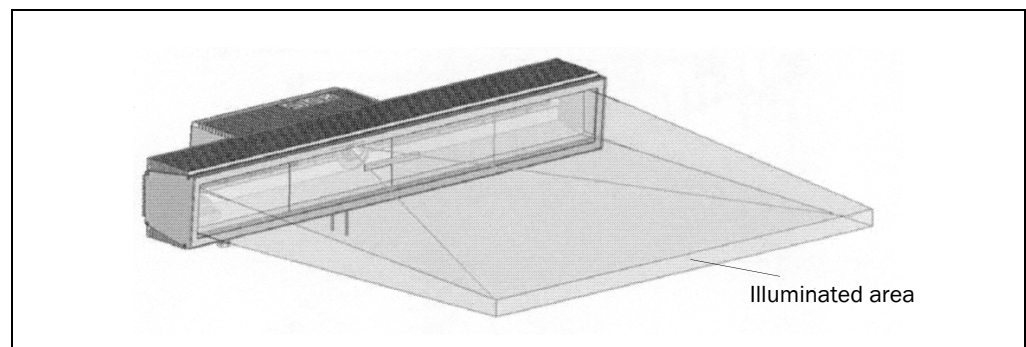

Fig. 3-6: Diagram of the illumination with illuminated area

During reading from above, the light is deflected onto the conveyor system using the **deflection mirror** (Fig. 3-7, Page 27).

ICR880/890



Fig. 3-7: ICR880/890 Camera System with deflection mirror for reading from above

The illumination is controlled by the Camera and can be switched on permanently or for the duration of the internal reading gate.

If the reading gate does not run to the end due to an error (e.g. when the conveyor system stops), the illumination automatically switches off once the settable timeout has expired. In order to prevent epilepsy, the minimum power-on time of the illumination is 3 s.



The illumination mode and the timeout for the ICI890 Illumination can be configured using the SOPAS-ET Configuration Software:

PROJECT TREE, ICR880/890, PARAMETER, READING CONFIGURATION, ILLUMINATION CONTROL, register tab ILLUMINATION MODE

3.4.5 Position

To ensure correct functioning of the Camera System, the position and angle of the camera and the deflection mirror have to be adjusted to the conveyor level.

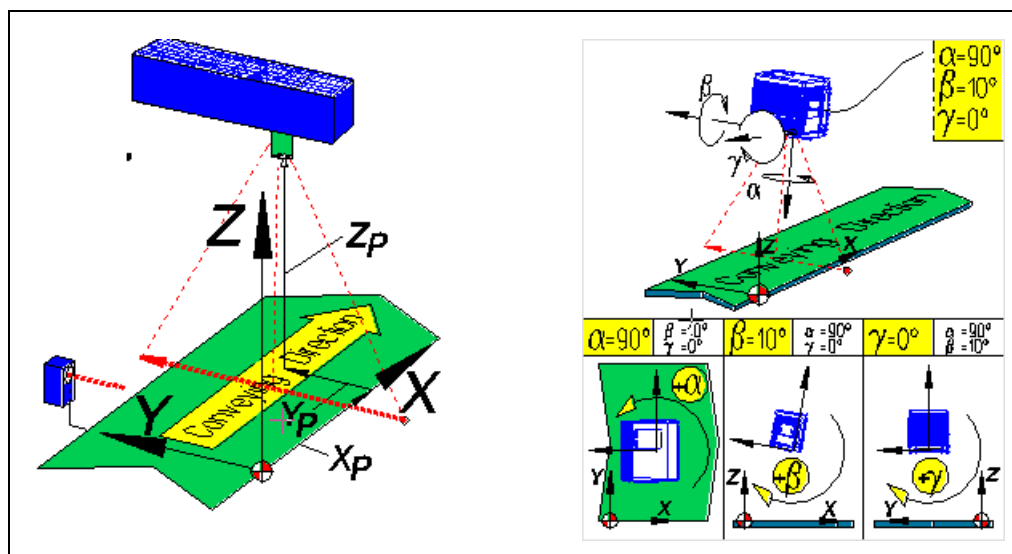

Fig. 3-8: Position of the ICR880/890 Camera System and the tilt angle

The position of the object trigger control (photoelectric reflex switch) on the outer right-hand edge of the conveyor system is considered the point of reference, as viewed in the direction of transport.

The α and γ angles must be set depending on the position of the Camera System (e.g. on top or at the side). In order to prevent direct reflectance, the light must be incident at an angle of approx. 15° ($\beta = \text{skew}$) on the object surface against the direction of transport.



The position and the angle of the camera and the deflection mirror can be configured using the SOPAS-ET Configuration Software:

PROJECT TREE, ICR880/890, PARAMETER, POSITION, register tabs COORDINATES and ANGLES

3.4.6 Increment configuration

In order to control the camera line frequency, the Camera System requires information on the conveyor speed. An external **incremental encoder** delivers pulses which are used to determine the current conveyor speed.

The conveyor speed results from the number of pulses and the resolution of the external incremental encoder.



The increment source and resolution/speed can be configured using the SOPAS-ET Configuration Software:

PROJECT TREE, ICR880/890, PARAMETER, INCREMENT CONFIGURATION, register tab INCREMENT

3.4.7 Image acquisition

The recorded image can be generated irrespective of the decoding result for further processing via the GBit Ethernet interface. This enables, e.g., an analysis if decoding has been unsuccessful.

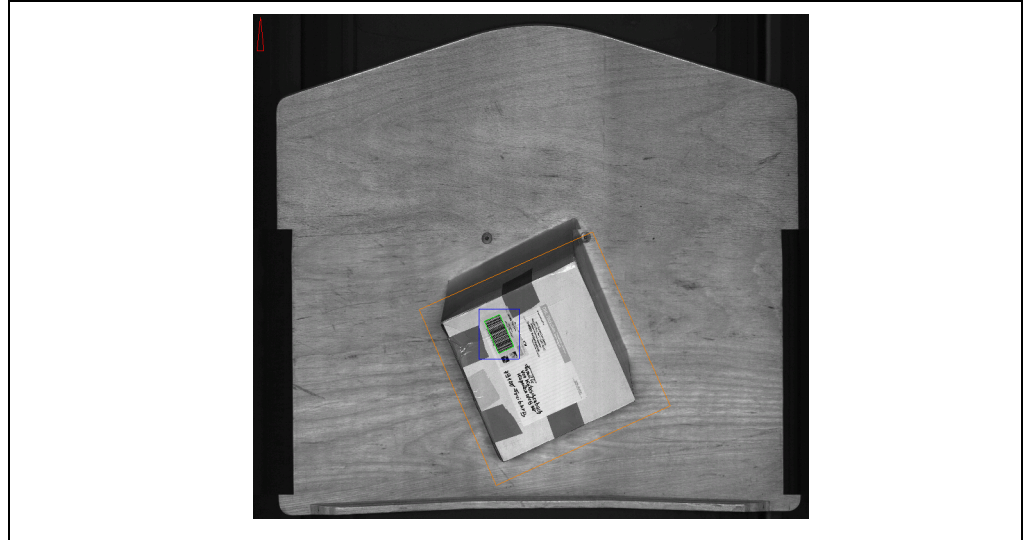

Fig. 3-9: Example of an image recording for analysis

If data processing has been successful (decoding), the marking of the corresponding image areas can also be displayed.



The image format and the scaling/quality can be configured using the SOPAS-ET Configuration Software:

PROJECT TREE, ICR880/890, PARAMETER, IMAGE OUTPUT, register tabs GENERAL, IMAGE FILENAME and JPEG OUTPUT

Decoding

The recorded image is analyzed by the ICR880/890 System. The results are shown as:

- Blue rectangles: regions of Interest
- Green rectangles: successful decoding

3.4.8 Code configuration

The ICR880/890 Camera System can decode the following code types:

1D codes (bar codes)

- Codabar
- Code 39
- UPC/EAN family
- 2/5 Interleaved
- Code 93
- Code 128 family

2D codes

- Data Matrix EEC200
- Maxicode
- PDF417

- QR code



The code types for 1D and 2D codes can be selected using the SOPAS-ET Configuration Software:

PROJECT TREE, ICR880/890, PARAMETER, 1D CODE, register tab SYMBOLOGIES

PROJECT TREE, ICR880/890, PARAMETER, 2D CODE, register tab SYMBOLOGIES

The selected code types can be configured individually. The SOPAS-ET Configuration Software has individual register tabs for each type.

3.4.9 Data processing

Tracking operation

During the reading process, a **maximum of 10 objects** can be simultaneously situated, one behind the other, in the tracking operation, i. e. the Camera System must be able to unambiguously assign the read codes to the objects (*Fig. 3-10, Page 30*). A reading pulse sensor controls initiation of the reading process at the start of the reading area as standard (see *Chapter 3.4.2 Object trigger control, Page 26*), the end is determined by the object release point. This also defines the size of the resulting reading area.

A regular pulse is required in order to track objects in the reading area. This is generated by the external incremental encoder, which delivers a constant pulse at least every 10 mm (394 mil) of movement in the direction of transport (see *Chapter 3.4.6 Increment configuration, Page 28*). This allows the Camera System to generate a clear display of the distance between the reading pulse sensor and the object release point. Any fluctuations during startup of the conveyor technology or reductions in speed caused by heavy objects are also detected. For clear separation of consecutive objects, a gap of at least 50 mm (1.97 in) is required. Reading results for an object are displayed after the rear edge of the object has passed the object release point. Alternatively, the reading process can be initiated by a command string via the data interface.

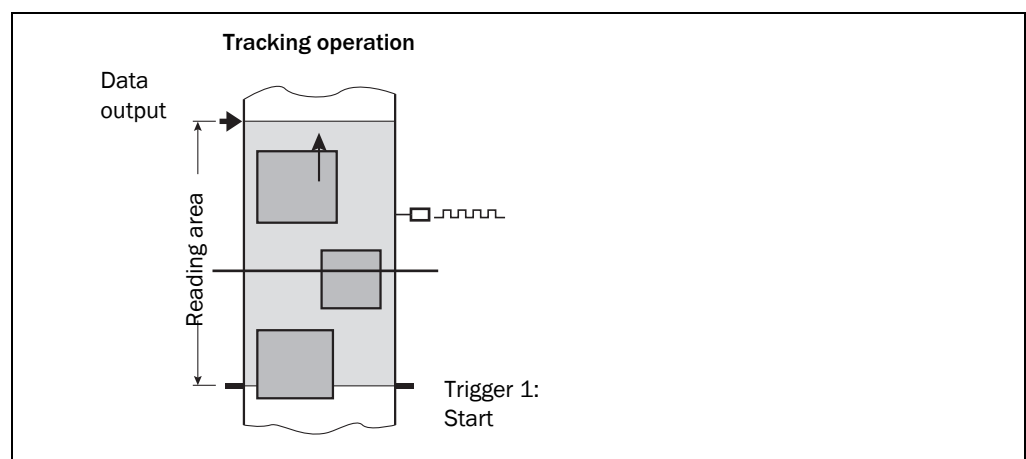

Fig. 3-10: Reading operation mode of the Camera System in stand-alone operation



The reading operation mode and object release point can be configured using the SOPAS-ET Configuration Software:

PROJECT TREE, ICR880/890, PARAMETER, DATA PROCESSING, register tab TRACKING